

FOREWORD

Thank you for purchasing the paperless recorder!

The user's manual contains useful information about the functions of the instrument, installation, wiring, operation procedures, and troubleshooting. To ensure correct use, please read this manual thoroughly before operation. Keep this manual in a safe place for quick reference in the event a question arises.

Notes

- The contents of this manual are subject to change without prior notice as a result of continuing improvements to the instrument's performance and functions.
- Every effort has been made in the preparation of this manual to ensure the accuracy of its contents. However, should you have any questions or find any errors, please contact us.
- Copying or reproducing all or any part of the contents of this manual without our permission is strictly prohibited.

Revisions

February, 2012, First edition

SAFETY PRECAUTIONS

Make sure to comply with the following safety precautions. If the instrument is used in a manner not specified in this manual, the protection provided by the instrument may be impaired. We assume no liability for the customer's failure to comply with these requirements.

WARNING

- **Power Supply**

Before connecting the power cord, ensure that the power supply voltage matches the voltage rating for the instrument.

- **Protective Grounding**

Make sure to connect the protective grounding to prevent electric shock before turning ON the power.

- **Necessity of Protective Grounding**

Never cut off the internal or external protective grounding wire or disconnect the wiring of the protective grounding terminal. Doing so poses a potential shock hazard.

- **Defect of Protective Grounding**

Do not operate the instrument when the protective grounding or the fuse might be defective. Also, make sure to check them before operation.

- **Do not operate in explosive atmosphere**

Do not operate the instrument in the presence of flammable liquids or vapors. Operation of any electrical instrument in such an environment constitutes a safety hazard.

- **Do not remove covers**

Some areas inside the instrument have high voltages. Do not remove the cover if the power supply is connected. The cover should be removed by our qualified personnel only.

- **External Connection**

Connect the protective grounding before connecting to the item under measurement or control unit.

- **Damage to the protection**

Using the instrument in a manner not specified in this manual may damage the instrument's protection.

CONTENTS OF THE PACKAGE

Unpack the box and check the contents before operating the paperless recorder. If some of the contents are not correct or missing or there is any physical damage, contact us or the dealer which you purchased it.

Standard Accessories

The following standard accessories are supplied with the instrument. Make sure that all items are present and undamaged.

No.	Name	Unit	QTY	NOTE
1	Paperless record	pcs	1	
2	User's Manual	Book	1	
3	Mounting bracket (with screws)	pcs	2	
4	Application	set	1	
5	Standard Software (CD)	set	1	
6	U disk	pcs		optional
7	RS-232C lines	pcs		optional
8	RS-232C/485 convert modula	pcs		optional
9	RS-232C/CAN convert modula	pcs		optional
10	Micro printer (accessory)	pcs		optional
11	Crate	pcs		optional

CONTENTS

CHAPTER 1 TECHNICAL INDEX	7
1.1 INPUT FUNCTION.....	7
1.2 DISPLAY AND STORAGE FUNCTION.....	8
1.3 OUTPUT FUNCTION (OPTION).....	9
1.4 24VDC TRANSMITTER POWER SUPPLY OUTPUT (OPTION).....	9
1.5 COMMUNICATION FUNCTION (OPTION).....	10
CHAPTER 2 INSTALLATION AND WIRING.....	11
2.1 PRECAUTIONS OF USE OF THE INSTRUMENT.....	11
2.2 INSTALLING INSTRUMENT.....	12
2.3 INPUT/OUTPUT SIGNAL WIRING.....	14
2.4 RELAY OUTPUT WIRING (OPTION).....	17
2.5 POWER WIRING.....	18
2.6 24VDC TRANSMITTER POWER SUPPLY WIRING (OPTION).....	20
2.7 RS232C/RS485 COMMUNICATION WIRING.....	22
CHAPTER 3 KEYBOARD FUNCTION AND OPERATION	23
3.1 NAMES OF PARTS AND FUNCTIONS.....	23
3.2 USING THE EXTERNAL THE STORAGE MEDIUM.....	23
3.3 RUN MODE.....	25
3.4 OVERVIEW SCREEN.....	26
3.5 BAR GRAPH DISPLAY.....	27
3.6 REAL-TIME TREND CURVE.....	28
3.7 ALARM INFORMATION.....	29
3.8 HISTORY CRUVE.....	30
3.9 POWER-DOWN INFORMATION.....	31
CHAPTER 4 SETTING SYSTEM PARAMETERS.....	32
4.1 CONFIGURE.....	32
4.2 SYSTEM CONFIGURATION	33
4.3 DISPLAY CONFIGURATION.....	35
4.4 INPUT CONFIGURATION.....	36
4.5 ANALOG OUTPUT CONFIGURATION.....	39
4.6 BACKUP DATA.....	40
4.7 PRINT DATA.....	41
CHAPTER 5 OTHER STANDARD FUNCTIONS.....	42

CHAPTER 1: TECHNICAL INDEX

1.1 INPUT FUNCTION

● Number of measurement channels/Scan interval

The number of measurement channels can be selected from 1 to 16.
The scan interval of measurement is set to 1 second.

● Input type and computation

You can select the input type of a measurement channel from DC voltage, DC current, thermocouple, resistance, frequency signal. You can also perform computation on the measured data such as the “square root”.

For procedure related to setting the different modes, see section 『Input configuration』 .

Input mode	Measuring range
DC current	4-20mA; 0-10mA;0-20mA
DC voltage	0-20mV;0-100mV;0-5V;1-5V
Resistance	0-400 Ω
Thermocouple	S,B,K,T,E,J,R,N,F1,F2,WRe3-25,WRe5-26
Resistance	PT100,Cu50,G53,Cu100,BA1,BA2
Frequency	0 to 5000Hz

1.2 DISPLAY AND STORAGE FUNCTION

● Common items related to the Display

➤ LCD and the Screen Configuration

The Instrument has a 5.7” TFT color LCD(320-by-240 dot resolution).

➤ Status display section

Displays the data and time, USB contact (option), cycle display condition and so on. For details, see section Explanation of the Status Display Section.

➤ Data Display Section

Displays the operation screen such as the trend, digital, alarm summary and print operation.

Displays the setup screen for the setting and basic setting modes when the instrument is being configured.

➤ Operation screen

The mode is entered when the power is turned ON.

Displays various operation screens such as digital, trend, alarm summary, historical trend, data print (option) and data backup display (option), accumulative report (option).

➤ Setting Mode

The various functions of the instrument are configured using the setting mode.

This screen is used to set the signal types, input range, filter, alarm, system time, etc.

- **Storage function**

External storage media and internal memory

The capacity of the internal memory for acquiring display data are 64-248MB flash memory(option) and 64KB SRAM.

Various data can be saved to the USB disk. The capacity is from 1GB to 16GB.

1.3 OUTPUT FUNCTION (OPTION)

Transmitter output

Measured and computed data can be transmitted and output as an analog signal.

The signal type of transmitter output is 4 to 20mA.

The instrument provide MAX 8 output channels.

The maximum load allowed to each channel is 750Ω.

For details, see section 『Output configuration』 .

1.4 24VDC TRANSMITTER POWER SUPPLY

OUTPUT (OPTION)

Provides 24 VDC power to transmitters.

The instrument provides MAX 16 power supply channels. The maximum current that can be provided to each channel is 30mA.

1.5 COMMUNICATION FUNCTION (OPTION)

The instrument can communicated with serial interface (RS232C or RS485), and also can print data by micro printer.

- **RS232C/RS485 Communication**

Instrument can be connected to computer by cable network (485 network)、radio、GPRS and Modem.

RS232C or RS485 can be selected when the instrument communicates with PC by using the MODBUS-RTU protocol.

The Standard software also provided to users. You can use it to connect the configuration software.

- **Micro Printer**

The instrument can be connected contacts with the micro printer.

You can print history data and history curve manually.

Print display data will be automatic.

CHAPTER 2: INSTALLATION AND WIRING

2.1 PRECAUTIONS OF USE OF THE INSTRUMENT

Read the following precautions before using the instrument and the external storage medium.

Handling precautions

- Be careful when cleaning the instrument, especially any plastic parts. When cleaning, wipe with a dry, soft cloth. Do not use chemicals such as benzene or thinner, since these may cause discoloration and deformation.
- Keep electrically charged objects away from the instrument as this may cause malfunction.
- Do not apply shock to the instrument.
- If there are any symptoms of trouble such as strange odors or smoke coming from the instrument, immediately turn OFF the power and unplug the power cord. Then, contact the dealer or our company.

2.2 INSTALLING INSTRUMENT

● Instrument dimension

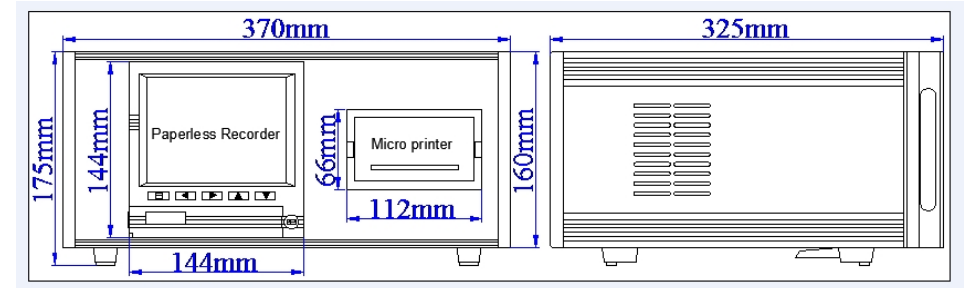

● Well-ventilated location

To prevent overheating, install the instrument in a well-ventilated location.

● Minimum mechanical vibrations

Choose an installation location with the minimum mechanical vibration.

NOTE

- Condensation may occur if the instrument is moved to another place where both the ambient temperatures and humidity are higher, or if the temperature changes rapidly. In this case, let the instrument adjust to the new environment for at least one hour before using it.
 - The lifetime of the LCD may be shortened if the instrument is used in a high-temperature environment over a long period of time.
-

- **Do not install the instrument in the following places**

- **In direct sunlight or near heat sources**

Install the instrument in a place with small temperature fluctuations near room temperature (23 °C). Placing the instrument in direct sunlight or near heat sources can cause adverse effects on the internal circuitry.

- **Where an excessive amount of soot, steam, moisture, dust, or corrosive gases are present**

Soot, steam, moisture, dust, and corrosive gases will adversely affect the instrument. Avoid such locations.

- **Near strong magnetic field sources**

Do not bring magnets or instrument that produce electromagnetic fields close to the instrument. Operating the instrument in strong magnetic fields can cause errors in the measurements.

- **Bad angle for viewing the screen**

Because the instrument uses a “liquid crystal display (LCD)”, it is difficult to view the display from an extreme angle. Please install the instrument so that the monitor can be viewed from the front.

2.3 INPUT/OUTPUT SIGNAL WIRING

- **Take the following precautions when wiring the input/output signal cables**

CAUTION

If a strong tension is applied to the cable wired to the instrument, the terminals of the instrument and/or the cable can be damaged. In order to prevent tension from being applied directly on the terminals, fasten all wiring cables to the rear of the mounting panel.

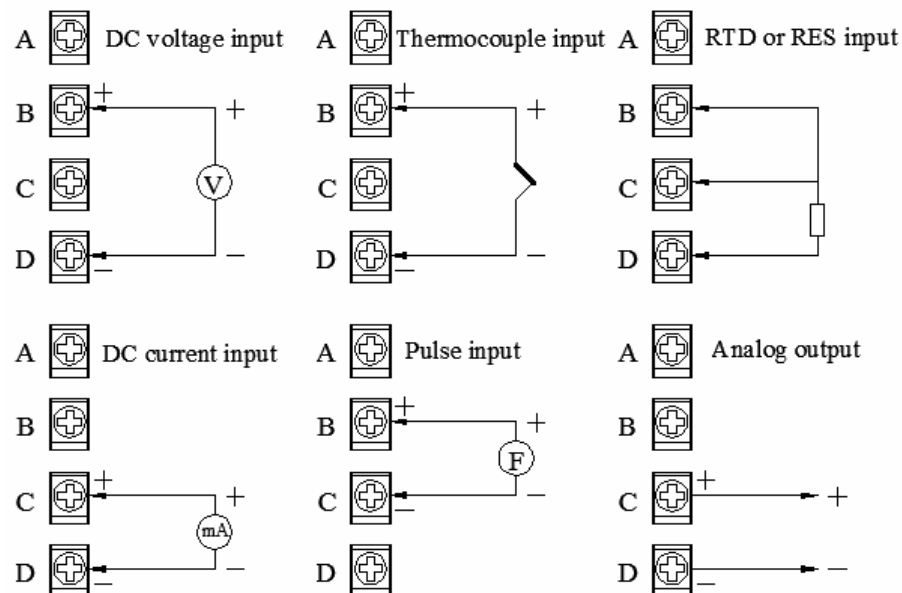

- **Take measures to prevent noise from entering the measurement circuit**

- Move the measurement circuit away from the power cable (power circuit) and ground cable.
- It is desirable that the item being measured does not generate noise.
- However, if this is unavoidable, isolate the measurement circuit from the item. Also, ground the item being measured.
- Shielded wires should be used to minimize noise caused by electrostatic induction. Connect the shield to the ground terminal of the instrument as necessary (make sure you are not grounding at two points).
- To minimize noise caused by electromagnetic induction, twist the measurement circuit wires at short, equal intervals.
- Make sure to earth ground the protective ground terminal through minimum resistance.

- **When using internal reference junction compensation on the thermocouple input, take measures to stabilize the temperature at the input terminal**

- Do not use thick wires which may cause large heat dissipation (cross sectional area 0.5 mm² or less is recommended).
- Make sure that the ambient temperature remains reasonably stable. Large temperature fluctuations can occur if a nearby fan turns ON or OFF.

- **Connecting the input wires in parallel with other devices can cause signal degradation, affecting all connected devices**

If you need to make a parallel connection, then:

- Ground the instruments to the same point.
- Do not turn ON or OFF another instrument during operation. This can have adverse effects on the other instruments.
- RTD can not be wired in parallel.
- Current signal can not be wired in parallel.

WARNING

- ✧ To prevent electric shock, ensure the main power supply is turned OFF.

- **Input terminal position and wiring diagram**

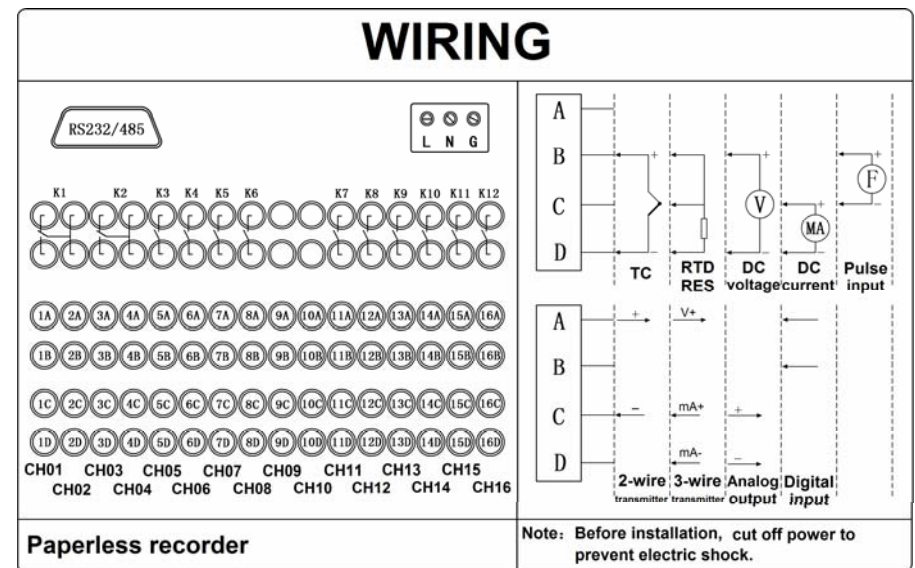

2.4 RELAY OUTPUT WIRING (OPTION)

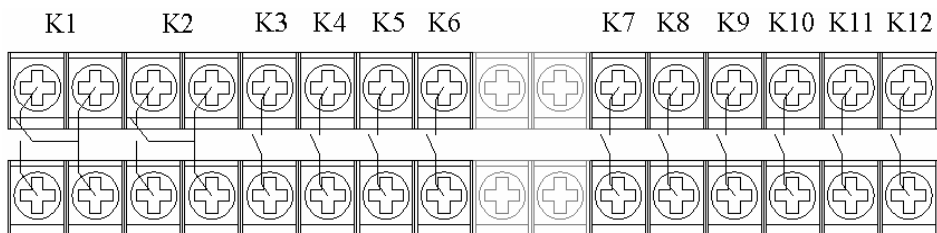

WARNING

- To prevent electric shock, ensure the main power supply is turned OFF.
- If a voltage of more than 30 VDC or 60 VDC is to be applied to the alarm output terminal, use ring-tongue crimp-on lugs with insulation sleeves on all terminals to prevent the wires from slipping out when the screws become loose. Furthermore, use double-insulated wires (dielectric strength of 2300VAC or more) for the signal wires on which a voltage of more than 30VAC or 60VDC is to be applied. For all other wires, use basic insulated wires (dielectrics strength of 1350 VAC). To prevent electric shock, attach the terminal cover after wiring and make sure not to touch the terminals.

● Wiring Procedure

- Turn OFF the instrument.
- Connect the alarm output cables to the terminal.
- When wiring is completed, power ON.

● Contact Specifications

Item	Specification
Output	Relay transfer contact (energize/de-energize switch able).
Output capacity	250VAC/1A 30VDC/1A

2.5 POWER WIRING

● Precautions to be taken when wiring the power supply

To prevent electric shock and damage to the instrument, observe the following warnings.

WARNING

- To prevent electric shock, ensure the main power supply is turned OFF.
- To prevent the possibility of fire, use 600 V PVC insulated wire (AWG18) or an equivalent wire for power wiring.
- Make sure to earth ground the protective earth terminal through a grounding resistance less than 100Ω before turning ON the power.
- Use crimp-on lugs (designed for 4 mm screws) for power and ground wiring termination.
- Make sure to provide a power switch (double-pole type) on the power supply line in order to separate the instrument from the main power supply. Put an indication on this switch as the breaker on the power supply line for the instrument. Switch Specification Rated power current 3A or more.
- Connect a fuse (between 2A and 15A) to the power line.

● Wiring Procedure

- Make sure the power is off.
- Connect the power supply wires and the protective ground wire to the power terminals.
- Connect to the power.

● **Power supply wiring terminal permutation**

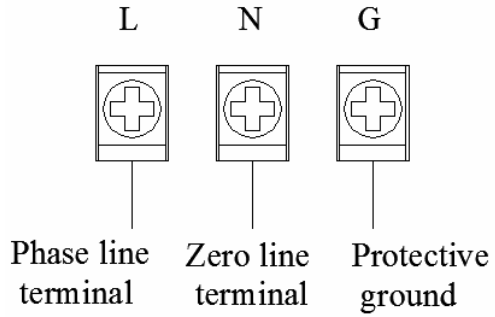

Power 100~240VAC

● **Specifications**

Item	Conditions
Input voltage	100VAC to 240VAC
Input frequency	50Hz/60Hz

2.6 24VDC TRANSMITTER POWER SUPPLY

WIRING (OPTION)

● **Transmitter power output**

CAUTION

- Never short-circuit the power supply terminals or apply an external voltage, otherwise it will damage to the instrument.

● **Wiring Diagram**

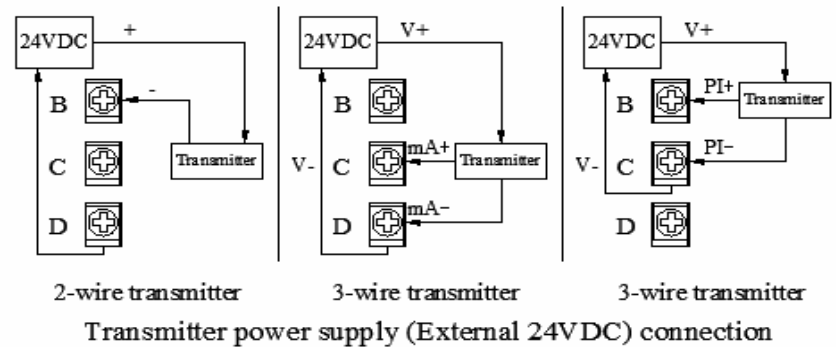
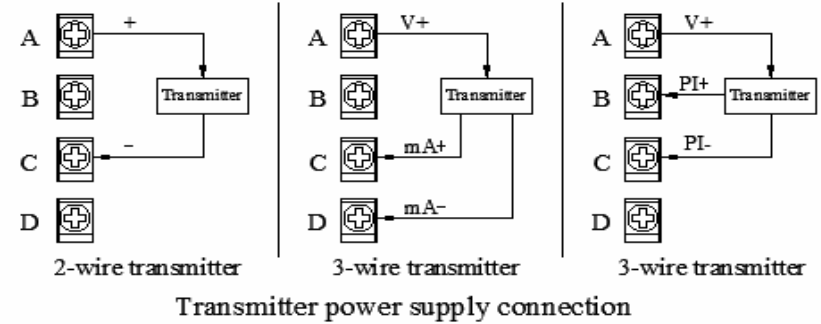

● **Connection Procedure**

- Turn OFF the power.
- Connect the power cord to the power connector on the rear panel of the instrument.
- When wiring is completed, power ON.

NOTE

To avoid connection failure, please tighten screws seriously while wiring.

● **Specifications**

Item	Conditions
Output voltage	22VDC ~ 25VDC (rate output current)
Maximum output current	40mA DC

2.7 RS232C/RS485 COMMUNICATION WIRING

● **Communication interface permutation**

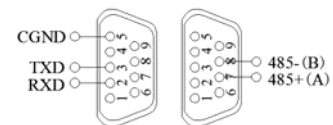

Communication interface

● **RS485 connect mode**

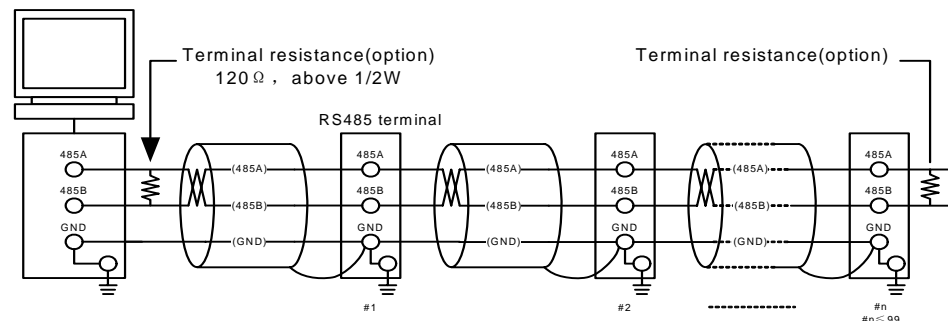

Don't connect terminal resistance between #1 and #n-1

● **RS232C connect mode**

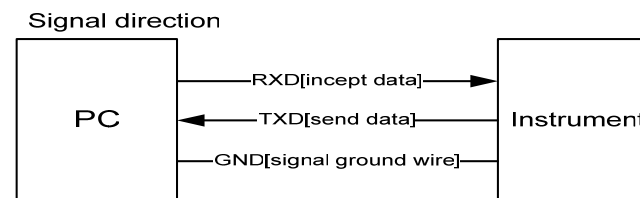









● **Communication Specifications**

Item	Specification
Baud rate	1200/4800/9600/19200/38400/57600

CHAPTER 3: KEYBOARD FUNCTION AND OPERATION

3.1 NAMES OF PARTS AND FUNCTIONS

Sign	Name	Description
	Key Menu	Used to switch operation screens or decimal places, etc.
	Key Left	Used to switch the channel or move the cursor forward, etc.
	Key Right	Used to switch the time scale or move the cursor backward, etc.
	Key Up	Used to switch or increase the value, etc.
	Key Down	Used to switch or decrease the value, etc.
	Key Enter	Used to activate the input box
 	Key Combination	Used to switch from operation mode to setting mode (Pressing for 1 second)

3.2 USING THE EXTERNAL THE STORAGE MEDIUM

This section describes the procedures to insert and remove the external storage medium.

USB disk can be used depending on the specification.

For the handling procedure of the storage medium, see section 『Backup data configuration』.

● Procedure

- Open the front cover and insert the medium into the drive until a click is heard.
- If the storage medium is detected, an external storage medium icon is displayed in the status display section of the screen.
- Accessing to the backup screen, the instrument backup the dates.
- Backup data

NOTE

- ✧ Keep the front cover closed during operation except when accessing the power switch and the external storage medium. This will protect the storage medium and the drive from external particles such as dust.
- ✧ Pay attention to anti-electrostatic measures when uses USB disk.
- ✧ Formatting the external storage medium before use. The instrument does not afford the format function.
- ✧ We recommend using our company's products.

● Specification

Item	Content
USB interface	Support USB2.0 protocol
Support U disk size	Maximum 16GB

3.3 RUN MODE

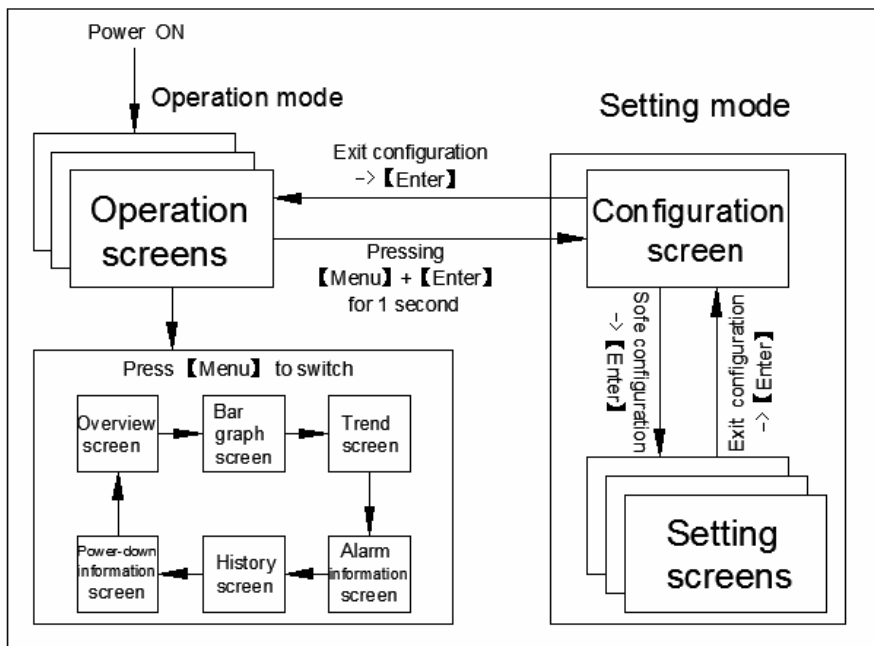

Mode Type	Description	Possible Operations
Operation mode	This mode is used for daily operation. This mode is entered when the power is turned ON.	Monitoring operation Data acquisition
Setting mode	This mode is used to configure the instrument operation such as input range and alarms. This mode is entered by pressing the left/right key in	Setting the operation Operation related to the file on the external storage medium.

the operation mode.

Measured data cannot be displayed in this mode.

Operations such as measurements, alarm detection, and data acquisition are continued.

3.4 OVERVIEW SCREEN

Display the measurement/computed data of 12 channels at the same time.

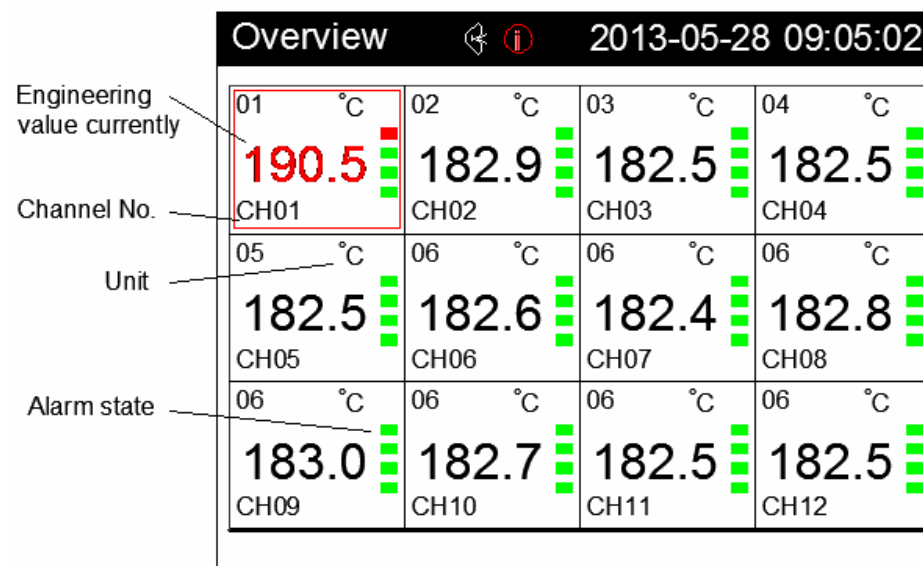

- **Engineering value currently**

Display the engineering data of the channel engineering.

3.5 BAR GRAPH DISPLAY

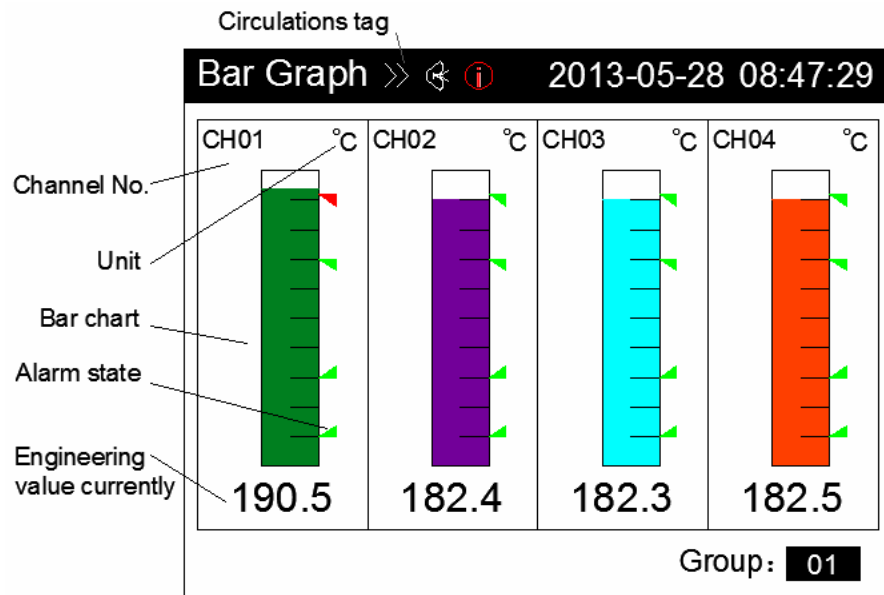

- **Indications of each channel's alarm state**

From top to down, High high alarm, high alarm, low alarm, low low alarm, red means alarm.

- **Bar chart**

Bar chart ruler has the length of 10 grids, and the length of filling color represent proportion in percent.

- **Circulations tag**

Circulation tag: The big digital display of every channel will be displayed with circulation.

No display: Static pictures and no circulation.

3.6 REAL-TIME TREND CURVE

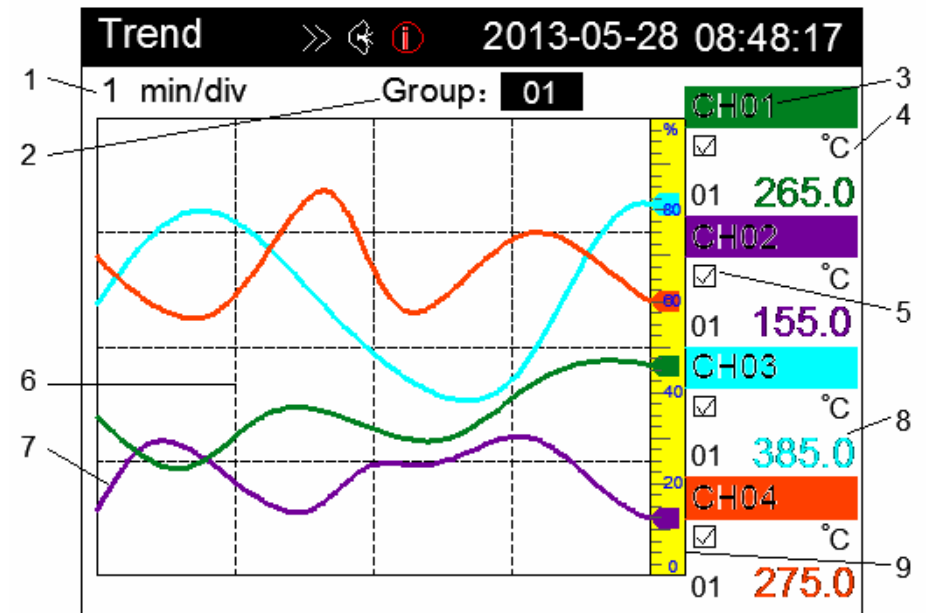

- 1、Trend cycle. Each grid means the length. the cycle is related with recording interval, Each grid time length= recording interval $\times 30$.
- 2、Show combination numbers.
- 3、Channel Number/tag.
- 4、Channel unit can be set.
- 5、Trend display symbol. “√” display, “×” hide.
- 6、Grid. estimate the time and data value.
- 7、Real time curve of channel. Most display 4 trends at the same screen.
- 8、Measurement of channel/computed data
- 9、Scale. Display percentage of the trend.

3.7 ALARM INFORMATION

Alarm Inf. 2013-05-28 09:18:24			
Chnl	Alarm Time	Undo Alarm Time	Type
01	2013-05-28 08:05:30	2013-05-28 08:05:35	HH
09	2013-05-28 08:06:22	2013-05-28 08:06:28	LL
03	2013-05-28 08:09:55	2013-05-28 08:11:00	HI
04	2013-05-28 08:13:10	2013-05-28 08:14:47	HH
02	2013-05-28 08:25:31	2013-05-28 08:30:26	LO
06	2013-05-28 08:30:29	2013-05-28 08:33:59	LL
12	2013-05-28 08:48:01	2013-05-28 08:48:11	HI
16	2013-05-28 08:56:17	2013-05-28 08:56:24	LL

R1	R2	R3	R4	R5	R6	R7	R8	R9
R10	R11	R12						

Page: 01

- 1、 Alarm time. Displayed the alarm occur time
- 2、 Undo alarm time. Displayed the alarm undo time
- 3、 Alarm channel.
- 4、 Alarm type (HH、 HI、 LO、 LL) .
- 5、 Relay state. Display current relay output state.

Relay type	Normal open relay	Normal closed relay
Green	Open	Close
Red	Close	Open

- 6、 Page. Each page screen 8set working information. Use [up and down Keys] to inquire next page.

3.8 HISTORY CRUVE

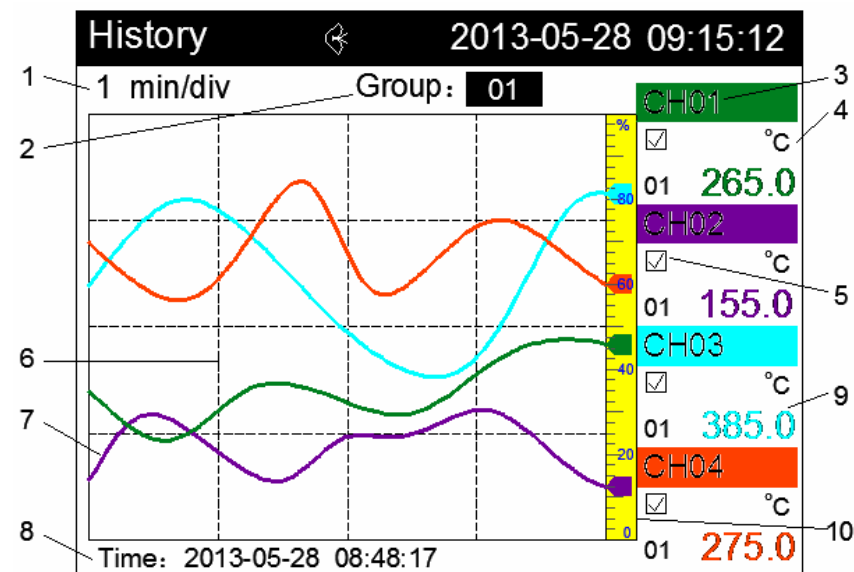

- 1、 Trend cycle. Each grid means the length. the cycle is related with recording interval, Each grid time length= recording interval ×Zoom multiple×30.
- 2、 Show combination numbers.
- 3、 Channel Number/tag.
- 4、 Channel unit can be set.
- 5、 Trend display symbol. “√” display, “×” hide.
- 6、 Grid. Estimate the time and data value.
- 7、 History curve of channel. Most display 4 trends at the same screen.
- 8、 Searching time. Uses [left] and [right] to move cursor to set the data time to a desired point by using [Up] and [Down]. Once [Enter] is pressed, the curve will be moved to the fixed point automatically.
- 9、 Historical data of channels. Show the data of channels that the Meter recorded.
- 10、 Scale. Display percentage of the trend.

3.9 POWER-DOWN INFORMATION

Power Inf.		2013-05-28 09:21:37	
Index	Power-down Time	Power-up Time	
01	2013-05-28 15:49:30	2013-05-28 16:00:00	
02	2013-05-28 16:05:02	2013-05-28 16:07:10	
03	2013-05-28 16:10:55	2013-05-28 16:11:05	
04	2013-05-28 16:15:28	2013-05-28 16:16:13	
05	2013-05-28 16:18:44	2013-05-28 16:30:09	
06	2013-05-28 16:32:01	2013-05-28 16:38:56	
07	2013-05-28 16:40:08	2013-05-28 16:42:35	
08	2013-05-28 16:44:09	2013-05-28 16:57:20	
		Page: 01	

- 1、 Every event record serial number.
- 2、 Power-down time. Power-down time of the instrument.
- 3、 Power-on time. Power-on time of the instrument.
- 4、 Page. Each page screen 8set working information. Use [up and down Keys] to inquire next page.

CHAPTER 4: SETTING SYSTEM PARAMETERS

4.1 CONFIGURE

● Procedure

Press [Enter] and [Menu] concurrently, holding 1 or 2 seconds. You enter into the configuration page. Use [Arrow] and [Enter] key, enter the password.

Configure
2013-05-28 08:32:36

Password: Please enter

System

Display

Input

Output

Backup

Print

Exit

NOTE

It is a unique password to modify configuration parameters. Once it is forgotten, it can not be modified those parameters.

The initial password is 000000, after purchasing instrument, it is better for users to amend it as soon as possible and preserve it properly.

4.2 SYSTEM CONFIGURATION

System		2013-05-28 08:35:21	
DateTime:	<input type="text" value="2013-05-28 08:32:36"/>		
Password:	<input type="text" value="00 00 00"/>	Channels:	<input type="text" value="16"/>
Interval:	<input type="text" value="01"/> s	Mode:	<input type="text" value="Print"/>
Baudrate:	<input type="text" value="1200"/>	Addr:	<input type="text" value="01"/>
Switch:	<input type="text" value="No"/> <input type="text" value="00"/> s		
CJC:	<input type="text" value="Auto"/> <input type="text" value="20"/> °C		
Key tone:	<input type="text" value="Yes"/>	Test:	<input type="text" value="Yes"/>
<input type="button" value="Clear Power Inf"/> <input type="button" value="Clear Alarm Inf"/> <input type="button" value="Default Setting"/>			
V1.5.2 2013-01-02			<input type="button" value="Exit"/>

- **Setting time**

Setting the current date and time of the instrument.

NOTE

After setting system data/time, those historical data stored in instrument is invalid.

New and effective data begins after setting system data/time.

Before setting system data/time, please backup history data.

- **User password**

User password authority set.

- **Record interval**

Select 1 /2/4/8/12/24/36/60/120/180/240sec.

The instrument's sampling period is 1 second, so the minimum record interval is 1 second.

Increasing the records interval can extend prolong the length of time instrument data storage.

NOTE

Modify the record interval, those historical data stored in instrument is invalid. So before modifying record interval, please backup history data.

- **Automatic switching**

Automatic switch the groups of the trend screens or bar graph screen.

- **Cold Junction Compensation (CJC)**

CJC can tune compensation value of thermocouple.





- **Default settings**

Restore default settings.

4.3 DISPLAY CONFIGURATION

Display 2013-05-28 08:49:05

Group: 01

Curve1:	CH01	Color:	
Curve2:	CH02	Color:	
Curve3:	CH03	Color:	
Curve4:	CH04	Color:	

Exit

4.4 INPUT CONFIGURATION

Input 2013-05-28 08:44:58

Chnl:	01	Tag:	CH01		
Type:	K	Unit:	°C		
Range:	-148	1370	Acc: No		
Filter:	00	S	Cut: 0.0 %		
Adjust:	0	Sqrt:	No		
Alam:	HH	HI	LO	LL	Zone
Value:	1370	1000	-148	-148	0.0 %
Relay:	None	02	None	None	

- **Type**
Setting the type of the channel's input signal.
- **Unit**
Setting the unit of the channel's input signal.
- **Range**
Setting the low range and the high range of the channel's input signal.

NOTE

- The high and low range should not be the same.
- The low range is -999 and the high range is 9999.

Type	Measuring range
4 -20mA	4.00mA to 20.00mA
1 -5V	1.000V to 5.000V
0 -5V	0.000V to 5.000V
0-20mV	0.00mV to 20.00mV
0-100mV	0.0mV to 100.0mV
PI	0Hz to 5000Hz
Pt100	-99.9°C to 850.0°C
Cu50	-50.0°C to 150.0°C
Cu53	-50.0°C to 150.0°C
Cu100	-50.0°C to 150.0°C
BA1	-99.9°C to 650°C
BA2	-99.9°C to 650°C
S	-50°C to 1760°C
R	-50°C to 1680°C
B	250°C to 1820°C
K	-148°C to 1370°C
N	-148°C to 1300°C
E	-148°C to 1000°C
J	-148°C to 1200°C
T	-40.0°C to 400.0°C
WRE5-26	0°C to 2320°C
WRE3-25	0°C to 2320°C
F1	400°C to 1200°C
F2	700°C to 2000°C
Res	0Ω to 400Ω
Sin	Setting range at will

● **Filter**

$$\text{Show value} = \frac{\text{Last value} \times \text{Input filter} + \text{Current value}}{\text{Input filter} + 1}$$

● **Adjust**

Allow the user adjust the deviation value, value = measurement value +adjustable value

● **Alarm**

➤ Setting alarm values (HH、HI、LO、LL)

The value should be in the range of channels.

➤ Setting alarm backlash of threshold (Zone)

Avoid relay frequently when the value of signal is around alarming threshold.

➤ Setting relay-contact

When alarm occurs, output it to the relay with setting number.

When relay-contact is set to be zero, alarm will not be output to this relay. When multiple alarms are set to be output to the same relay, any alarm will make this relay operate.

➤ Alarm condition and Undo Alarm condition

Threshold type	Alarm condition	Undo Alarm condition
High High Limit	Channel value > High high threshold	Channel value < High high threshold -backlash
High Limit	Channel value > High threshold	Channel value < High threshold -backlash
Low Limit	Channel value < Low threshold	Channel value > Low threshold -backlash
Low Low Limit	Channel value < Low low threshold	Channel value > Low low threshold -backlash

4.5 ANALOG OUTPUT CONFIGURATION

Output			
2013-05-28 08:50:56			
	CH Output	CH Input	Action
Group1:	07	01	Direct
Group2:	08	02	Direct
Group3:	09	03	Reverse
Group4:	10	04	Reverse
Group5:	11	05	Reverse
Group6:	12	06	Reverse
Group7:	None	None	Direct
Group8:	None	None	Direct
			Exit

- **Channel input**

Setting the source of the value of channel output.

- **Action**

Under direct of AO 【Analog Output】 ,Transmitting range high limit to the output 20mA, Transmitting range low limit of output 4 mA; Under reverse of AO, Transmitting range high limit of output 4 mA, Transmitting range low limit of output 20mA.

4.6 BACKUP DATA

Backup Data	
2013-05-28 08:55:22	
Status:	On line
Channel:	01-16
Begin:	2013-05-28 08:32:36
End:	2013-05-28 08:55:22
File:	13052808.BIN
Progress:	<div style="width: 50%; background-color: black; height: 10px;"></div> 50%
<input type="button" value="Backup"/> <input type="button" value="Reset"/> <input type="button" value="Exit"/>	

- **Device Status**

Show mode of U disk, on line, off line, fault state, can not detect U disk [off line],error in the back processing[fault].

- **Begin/End time**

Begin time < End time ≤ System time

- **Progress bar**

Show the current progress of the backup process.

4.7 PRINT DATA

Print Data		2013-05-28 08:58:00	
Range:	2013-05-26	08:00:00	
	2013-05-28	08:58:00	
Begin:	<input type="text" value="2013-05-28"/>	<input type="text" value="08:57:50"/>	
End:	<input type="text" value="2013-05-28"/>	<input type="text" value="08:58:00"/>	
Channel:	<input type="text" value="01"/>		
Type:	<input type="text" value="Data"/>		
Interval:	<input type="text" value="01"/>		
Progress:	<div style="width: 50%; background-color: black; height: 15px;"></div>		50%
		<input type="button" value="Print"/>	<input type="button" value="Stop"/> <input type="button" value="Exit"/>

- **Begin/End time**

Begin time < End time ≤ System time.

- **Type**

Print the curve or data.

- **Interval**

The interval is according to unit recording interval.

- **Progress bar**

Show the current progress of the print process.

CHAPTER 5: OTHER STANDARD FUNCTIONS

- **Construction**

Item	Specification
Dimensions	370(W)×175(H)×325(D)
Weight	Approx 8.0 Kg

- **Functions related to time**

Item	Specification
Clock	Run between 2000 to 2099
Accuracy of clock	±10ppm (0 to 50°C), excluding a delay (of 1 second, maximum) caused each time the power is turned on.
Clock battery life	Approx 10 years

- **Standard Performance**

Item	Specification
Power supply voltage	220VAC
Power supply frequency	50Hz
Temperature	0°C to 50°C
Humidity	0% to 85%(RH)
Warm-up time	At least 30 minutes
Mounting position	inside

● Power supply

Item	Specification
Rated power supply voltage	220VAC
Allowable voltage range	100VAC to 240VAC
Rated power supply frequency	50Hz
Power consumption	24W or less

● Insulation

Item	Specification
Grounding resistance	Grounding resistance $\leq 10\Omega$

● Transport and Storage Conditions

Item	Specification
Ambient temperature	-10°C to 60°C
Ambient humidity	0% to 95%(RH)

● Standard Capability

Item	Specification
Display/measuring precision	Numerical value precision: Entire measuring range error $\leq 0.2\%F.S.$ Curve precision: 0.5%F.S

● Other Specifications

Item	Specification
Data retention	Approx 10 years