

Foreword

Thank you very much for using the paper recorder produced by our company!

This manual provides methods on performance indicators, installation and wiring, operation, parameter setting, fault diagnosis, etc. when using the paper recorder. Please read this manual carefully before using the paper recorder, and carry out specific operations after correctly mastering the use methods, so as to avoid unnecessary losses caused by wrong operations.

After you finish reading, please keep it in a place convenient for you to read at any time for reference during operation.

Packing Details



Paper Recorder

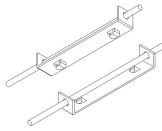

Mounting Bracket

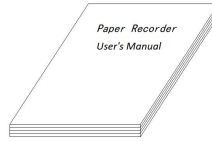

An Instruction Manual



Product Certificate / Warranty Card

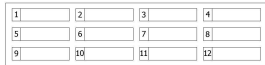

Channel ID Card

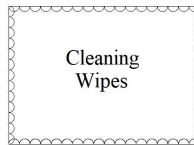

Cleaning Wipes

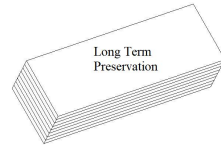

Record Printing Paper

No.	Name	Unit	QTY	NOTE
1	paper recorder	pcs	1	
2	User's Manual	book	1	
3	Mounting bracket (including screws)	pcs	2	For disc mounting and fixing
4	Product certificate / warranty card	pcs	1	
5	Record Printing Pape	pcs	4	
6	Channel ID Card	pcs	1	Used to identify channel names
7	Cleaning Wipes	pcs	1	Used to wipe the print head
8	2/3/4/8/12 core terminal blocks	pcs	n	Subject to physical objects
9	2-core power cord	pcs	1	optional
10	Data management software (CD)	pcs	1	optional
11	RS-232C Communication line	pcs	1	optional
12	RS-232C/485 conversion module	pcs	1	optional

Attention

- If the instrument is found damaged due to transportation when unpacking, please contact the manufacturer
- This series of instruments is suitable for general industrial occasions. If there are special use requirements, please set additional protective devices
- For your safety and the instrument, please do not install with electricity. Please use the power supply with rated voltage, and connect and ground it properly. After connecting the power supply, please do not touch the wiring terminal at the back of the instrument to prevent electric shock
- The instrument should be installed indoors, and the installation position should ensure smooth ventilation (to prevent the internal temperature of the instrument from being too high), avoiding rain and direct sunlight, and should not be installed in the following occasions:
 1. Occasions where the temperature and humidity exceed the service conditions
 2. Occasions with corrosive, flammable or explosive gases
 3. Occasions with a large amount of dust, salt and metal powder
 4. Occasions where water, oil and chemical liquids are easy to sputter
 5. Occasions with direct vibration or impact
 6. Occasion of electromagnetic generating source
- Corresponding shielding measures shall be taken for the instrument in the places close to the power line of the power supply, strong electric field, strong magnetic field, static electricity, noise or AC contactor
- To avoid measurement error, please use the corresponding compensation wire when the sensor is a thermocouple. When the

sensor is a thermal resistance, use three copper wires with the same specification and the resistance value is less than $10\ \Omega$, otherwise it will cause measurement error.

- In order to prolong the service life of the instrument, please maintain it regularly. Do not repair or disassemble the instrument by yourself. When wiping the instrument, please use a clean soft cloth. Do not dip in alcohol, gasoline and other organic solvents to clean, which may cause discoloration or deformation
- If the instrument has water, smoke, peculiar smell, abnormal noise, etc., please cut off the power supply immediately, stop using and contact the supplier or our company in time

Catalogue

一、 TECHNICAL INDICATORS	7
二、 INSTALLATION AND WIRING	10
2.1 INSTRUMENT DIMENSIONS	10
2.2 OPENING SIZE	10
2.3 INSTRUMENT INSTALLATION	11
2.4 INSTRUMENT WIRING	12
2.4.1 Wiring diagram	12
2.4.2 AC power input wiring	14
2.4.3 Input/Output Signal Wiring	14
2.4.4 Relay Contact Output Wiring	15
2.4.5 Transmitter distribution wiring	15
2.4.6 Communication interface definition and wiring	16
三、 DISPLAY AND RECORDING METHODS	17
3.1 INSTRUMENT PANEL	17
3.2 DISPLAY METHOD	17
3.3 RECORDING METHOD	17
四、 BASIC OPERATION AND OPERATION SCREEN	19
4.1 INSTRUMENT KEYS	19
4.2 PATROL DISPLAY SCREEN	20
4.3 GENERAL PICTURE	21
4.4 HISTORICAL TREND	21
4.5 POWER DOWN LIST	23
4.6 ALARM LIST	24
4.7 INPUT CONFIGURATION	25
4.8 OUTPUT CONFIGURATION	27
4.9 COMMUNICATION CONFIGURATION	29

4.10 DATA BACKUP	31
五、 PARAMETER SETTING AND AUXILIARY SCREEN	32
5.1 CONFIGURATION AND SYSTEM CONFIGURATION	32
5.2 AUXILIARY INTERFACE	34
六、 INSTRUMENT STRUCTURE AND MAINTENANCE AND SERVICE GUIDELINES	35
6.1 STRUCTURAL CHARACTERISTICS	35
6.1.1 Paper changing method	35
6.2 INSTRUMENT MAINTENANCE	36
6.3 SERVICE GUIDE	37
七、 FAULT ANALYSIS AND TROUBLESHOOTING	39

一、 Technical Indicators

● Display

Screen: 128 * 64 dot matrix liquid crystal display (OLED)

Accuracy: Display and measurement accuracy: $\pm 0.2\%$ F.S

Note: the cold end error of thermocouple should be removed

● Processor

The high-performance arm Cortex-M3 32-bit RISC core is adopted to realize multi-channel signal acquisition, recording, display and multi-channel alarm at the same time

● Enclosure

Using serial FRAM memory chip to store key information such as system configuration parameters

● Input Function

Input specification: Fully isolated universal input, maximum support for 10-way universal analog input

Voltage input: 0-5V, 1-5V, 0-20mv, 0-100mV

Current input: 0-10mA, 4-20mA, 0-20mA

Resistance Input: Res

Thermal resistance: PT100, Cu50, G53, Cu100, BA1, BA2

Thermocouple: S, B, K, T, R, E, N, J

Radiation Pyrometer: F1, F2

Tungsten rhenium: WRe3-25, WRe5-26

Note: Other input signals (such as switching input (DI), pulse input (PI), or graduation numbers (such as PT1000) should be indicated when ordering

- **Communication Function**

Communication interface: RS232C and RS485 communication interfaces are provided for users to choose, and Modbus RTU protocol is supported. Baud rate (1200、4800、9600、19200、38400、57600)

- **Printing function**

Distribution range: 800 thermal printing points within a 100mm range

Print Type: Curve Trend and Measurement Data

Paper feeding speed: 10 mm/h to 1990mm/h can be set

Printing depth: 0-3 optional, the larger the value, the deeper the printing

- **Power supply**

Power supply: 100 ~ 240VAC (rated power supply voltage 220VAC),50 / 60Hz AC power supply

- **Protection function**

Power outage protection: built-in memory protection parameters, permanently saved after power outage

Clock protection: Integrated hardware clock, accurate operation even after power failure

- **Error accuracy**

Thermocouple cold end compensation error: ± 2 °C

Clock error: ± 2 seconds / day

- **Working environment**

Working temperature: 0 ~ 50 °C (avoid direct sunlight)

Relative humidity: 0 ~ 85% R.H (no condensation)

Note: It is prohibited to work in flammable and corrosive environment

- **Transportation and storage environment**

Transportation and storage temperature: -20~60 °C (avoid direct sunlight)

Transportation and storage humidity: 5-95% R.H (without condensation)Net weight of instrument

- **Net weight:** $\leq 3.5\text{Kg}$

- **Technical indicators description**

Note: The technical index is the general index of this series of instruments, and the functional configuration shall be subject to the physical object.

- If the technical indicators are inconsistent with the physical instruments, the physical instruments shall prevail.

二、 Installation And Wiring

2.1 Instrument Dimensions

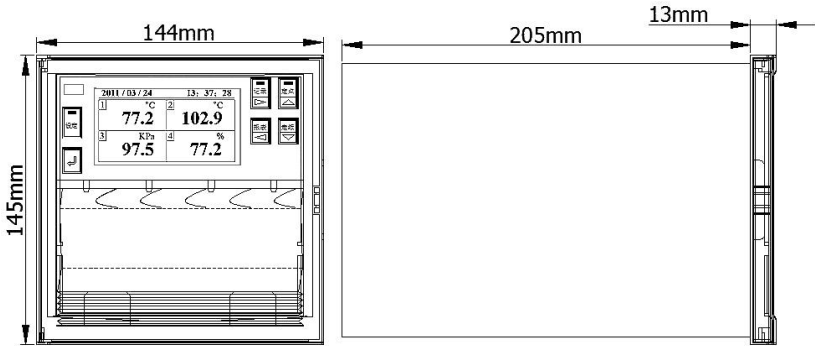

2.2 Opening Size

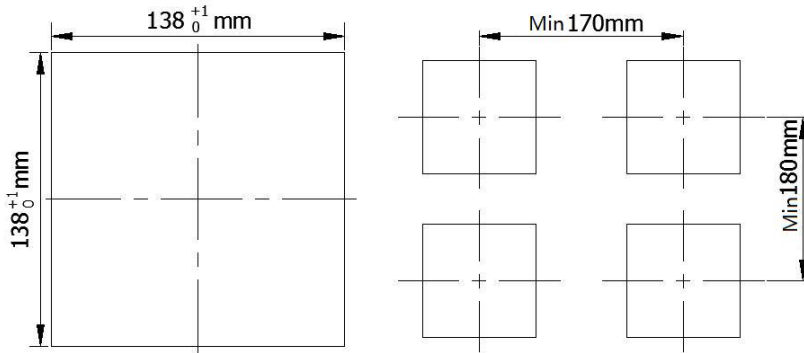

Opening size of single meter

Opening size of container gauge

When installing the containerized meter, refer to the minimum spacing between instruments recommended in the above figure to ensure necessary heat dissipation and loading and unloading space. The unit shown in the above figure is mm.

2.3 Instrument Installation

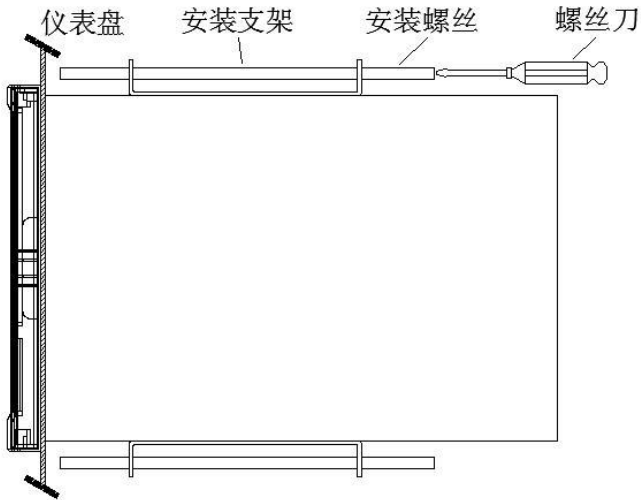

Installation method:

Step 1: push the instrument into the mounting hole from the front of the mounting panel (please use steel plate). The thickness of the installation panel is (1.5 ~ 6.5) mm.

Step 2: install the instrument with the mounting bracket as shown in the figure above (one bracket is installed on the left and right sides of the instrument, and the screws used for the mounting bracket of the instrument panel are M4 standard screws).

Step 3: after the instrument body is installed, the signal line and power line can be connected.

Note: When installing this instrument, please do not tilt it left or right, and try to install it horizontally (it can be tilted back $<30^\circ$).

Due to the need to remove the machine for maintenance, simply rotate the screw in reverse to remove the mounting bracket and gently pull out the instrument. Do not apply excessive force to avoid damaging the anti oxidation layer of the shell.

2.4 Instrument Wiring

2.4.1 Wiring diagram

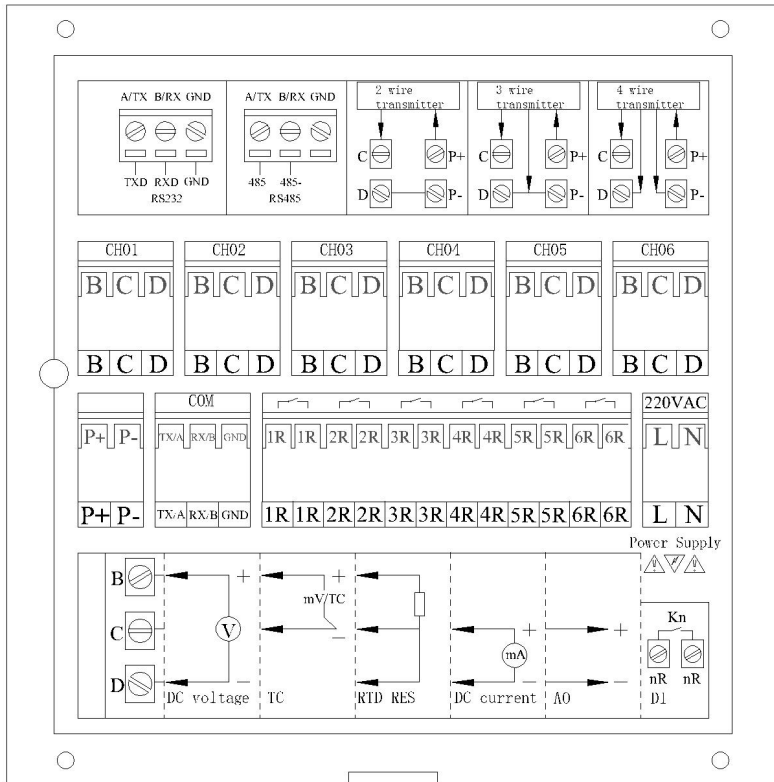

6-Channel Wiring Diagram

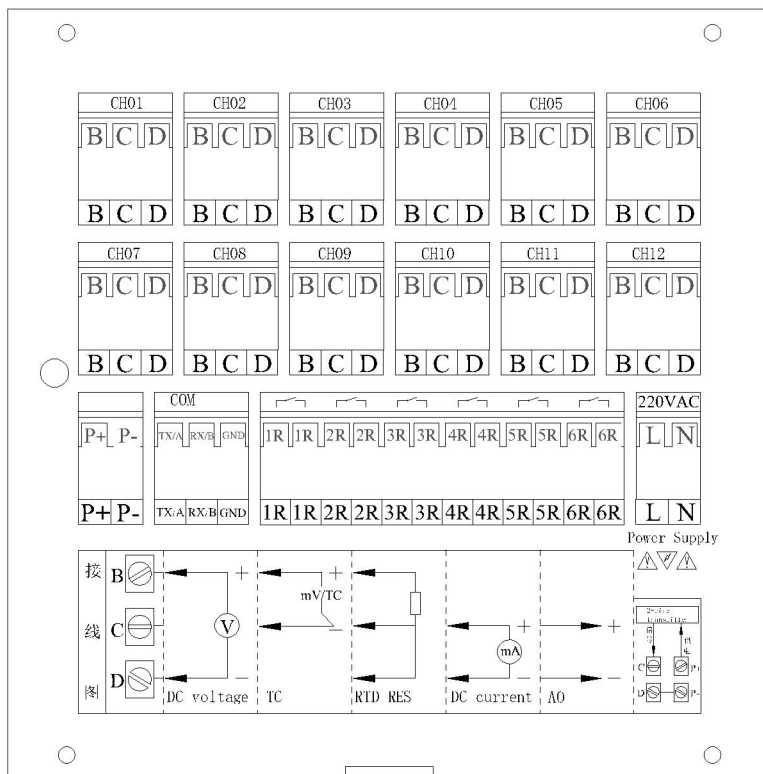

12-Channel Wiring Diagram

Note: Please wire correctly according to the wiring diagram after power outage, and live installation is prohibited.

This instruction provides the basic wiring diagram. When there is a conflict between the instrument function and the basic wiring diagram, please refer to the actual object.

2.4.2 AC power input wiring

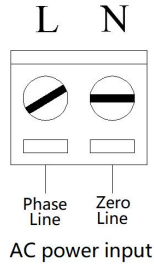

Note: The power supply voltage at the engineering site must be limited to the voltage range that the instrument can withstand.

2.4.3 Input/Output Signal Wiring

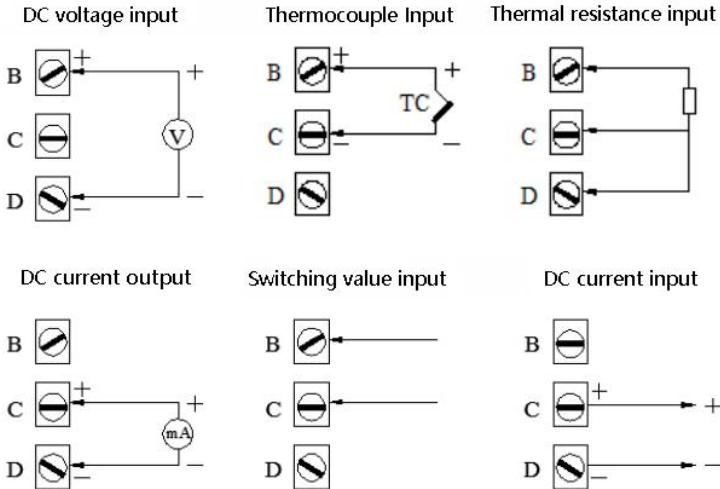

Note: When placing an order, it is necessary to specify the switch input. Once a channel's input signal is a switch signal, this channel will no longer support analog, thermal resistance, thermocouple, and other signals.

Other signals such as Pt1000, 0-10V, etc. need to be explained when ordering.

2.4.4 Relay Contact Output Wiring

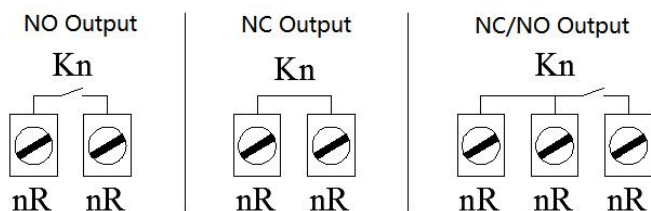

Note: $N=1,2,3,4,5,6$ (with a maximum of 4 channels for normally open and normally closed outputs), wiring wire cross-sectional area: $0.5-2.5\text{mm}^2$, torque: 50Nm . This machine is shipped in the normally open mode by default, please specify other modes when ordering.

2.4.5 Transmitter distribution wiring

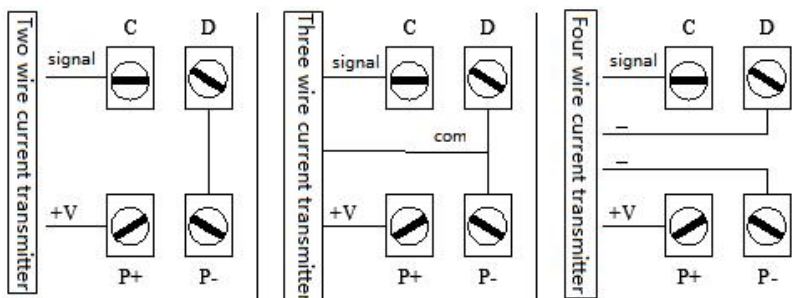

Transmitter wiring method (instrument feeding)

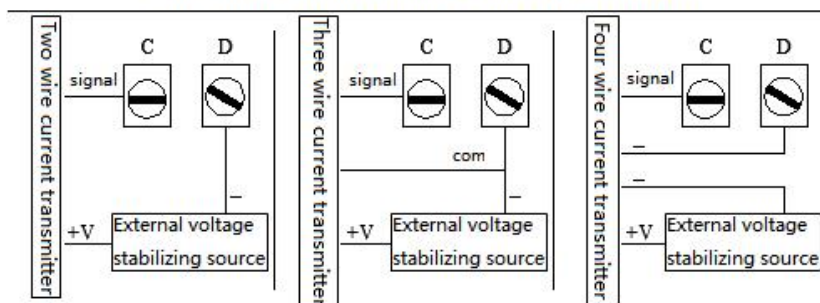

Transmitter wiring method (external voltage source)

Note: This machine is shipped with a default 24VDC power supply. Please specify other specifications when ordering.

When the power consumption of the transmitter exceeds the local feeding load capacity, please use an external voltage source for power supply.

2.4.6 Communication interface definition and wiring

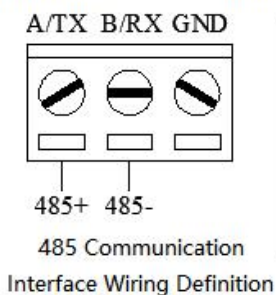
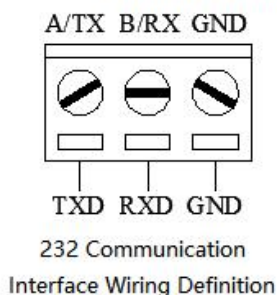
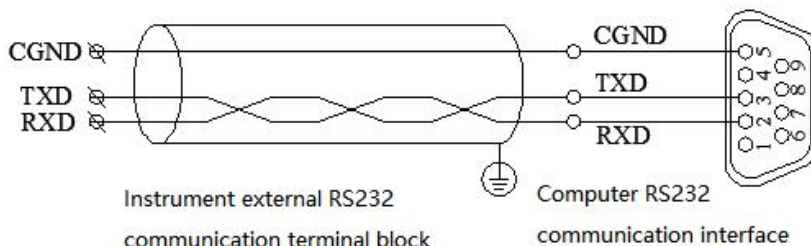

Attention:
Do not plug or unplug the communication interface with power. If you need to operate, please turn off the instrument power before proceeding.

Note: Please do not plug or unplug communication cables with power. If necessary, please perform the operation after the instrument power supply is turned off.

三、Display and recording methods

3.1 Instrument panel



3.2 Display method

✧ In the measurement state, display the channel number and measurement value.

✧ In the setting state, display the setting content.

✧ Display real-time time when all channels are closed.

✧ Six indicator lights are relay action number prompt lights

3.3 Recording method

✧ Print recording curve (recording status, recording indicator light on)

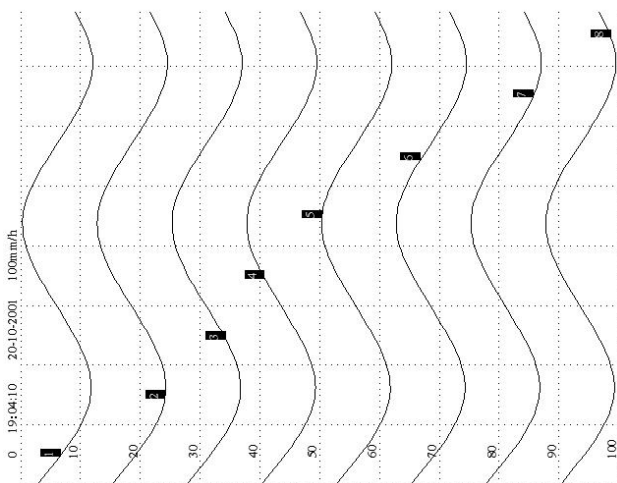

☉ Print setting parameters (when the record indicator light is off, press the [Report button])

Parameter	Chnl1	Chnl2	Chnl3	Chnl4	Chnl5	Chnl6	Chnl7	Chnl8
Signal A	4-20mA	Pt100	K	Cu50	0-20mV	0-5V	0-100mV	E
Point d	1	1	0	1	1	1	1	0
Single L L	0.0	-99.9	-148	-50.0	0.0	0.0	0.0	-148
Single H H	100.0	850.0	1370	150.0	100.0	100.0	100.0	1000
Print L C	20.0	0.0	0	0.0	0.0	0.0	0.0	0
Print H C	80.0	500.0	1000	100.0	100.0	100.0	100.0	1000
Alarm HH H	82.0 ①	850.0Nu	1370 Nu	150.0Nu	100.0Nu	100.0Nu	100.0Nu	1000 Nu
AlarmHI H	80.0 ②	500.0 ⑤	1370 Nu	150.0Nu	100.0Nu	100.0Nu	100.0Nu	1000 Nu
Alarm LO L	20.0 ③	0.0 ⑥	-148 Nu	-50.0Nu	0.0 Nu	0.0Nu	0.0Nu	-148 Nu
Alarm LL L	18.0 ④	-99.9Nu	-148 Nu	-50.0Nu	0.0 Nu	0.0Nu	0.0Nu	-148 Nu
AlmDelay E	1.0	1.0	0	0.0	0.0	0.0	0.0	0
Adjust J	0.0	0.0	0	0.0	0.0	0.0	0.0	0
Filter F	0	0	0	0	0	0	0	0
Speed P	100							
Staff b	0							
Gap U	60							
Year yy	2002							
Date dd	06-10							
Time tt	10:20:09							
Depth dA	1							

☉ Print measurement data (when the recording indicator light is on, press the [Report button])

2002-06-10	Chnl1	Chnl2	Chnl3	Chnl4	Chnl5	Chnl6	Chnl7	Chnl8
10:09:01	50.0	265.0	500	140.0	90.0	90.0	90.0	500

四、BASIC OPERATION AND OPERATION SCREEN

4.1 INSTRUMENT KEYS

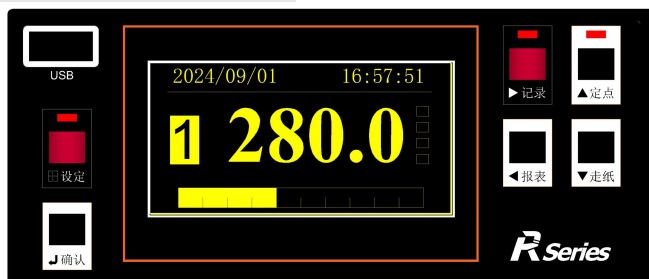

Keyboard Function

Mode	Symbol	Name	Function
Measurement Mode Usage		Record Key	Press once, the recording indicator light will light up, and the instrument will print the curve according to the set method Press again, the recording indicator light goes out, and the instrument does not record, only displays the measured value
		Fixed-point Key	Press once to fix the current display channel Press again to display the measurement data values of each channel in a circuit
		Paper Feed Key	Press once to quickly feed the instrument Press again to restore the original state and stop paper feeding
		Report Key	When the recording indicator light is off, press once to print all set parameters, current time, and paper speed When the recording indicator light is on, press once to print the current measurement values, current time, and paper speed of each channel
Set Mode Usage		Setting Key	Press once for three seconds to enter parameter setting mode configuration, and the setting indicator light will be on Press again, set the indicator light to turn off and return to the measurement mode state
		OK	Execute cursor function or edit cursor data, etc
		Right	Move cursor to the right/back, etc
		Left	Move cursor left/forward, etc
		Up	Move the cursor up (configuration screen), switch selection, increase the data value where the cursor is located, etc
		Down	Move the cursor down (configuration screen), switch selection, reduce the data value where the cursor is located, etc

Note: This instrument has six operating buttons, divided into

measurement mode and setting mode. There are four operating buttons in measurement mode and six operating buttons in setting mode. Please refer to the above icon for specific button functions.

4.2 Patrol display screen

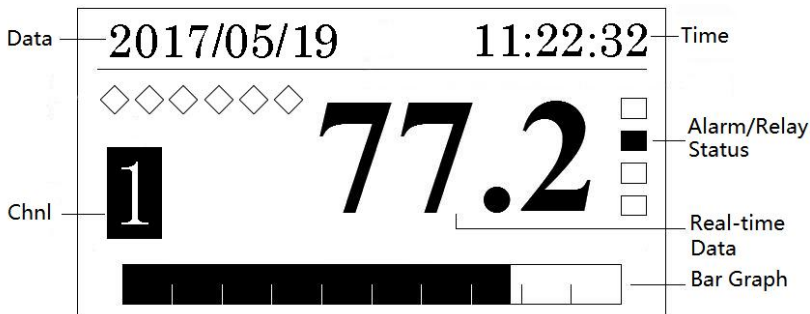

① Alarm status: from top to bottom, the upper limit HH, the upper limit Hi, the lower limit lo, and the lower limit ll are respectively. The hollow box indicates that the alarm is normal, and the solid box indicates that the alarm is out of limit.

② Channel tag number: displays the engineering tag number corresponding to the channel, where 1 represents the first channel, 2 represents the second channel, and so on. It is fixed and cannot be configured.

③ Real time data: display the quantity measurement / calculation data of this channel.

④ Signal type: the signal type input by the primary instrument or detection element of the current channel.

⑤ Relay status: relay output display, in which the open circle represents the non action status of the relay corresponding to the value in the corresponding circle, the solid circle represents the output alarm status of the relay corresponding to the value in the corresponding circle, the value 1 represents the K1 relay, the value 2 represents the K2 relay, and so on.

⑥ Cycle status: if automatic switching is enabled in the system

configuration, the digital display / curve screen of each channel will be cycled and the switching interval can be adjusted; When the automatic switching time is 0s, there is no display.

4.3 GENERAL PICTURE

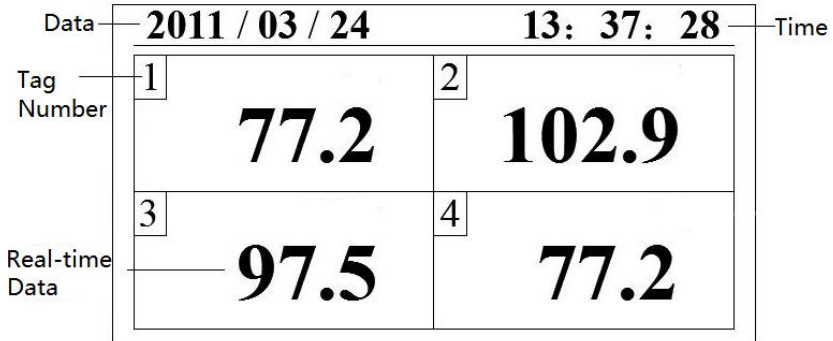

① Channel tag number: displays the engineering tag number corresponding to the channel, where 1 represents the first channel, 2 represents the second channel, and so on. It is fixed and cannot be configured.

② Real time data: display the quantity measurement / calculation data of this channel.

③ System time: displays the current time and date of the system.

4.4 HISTORICAL TREND

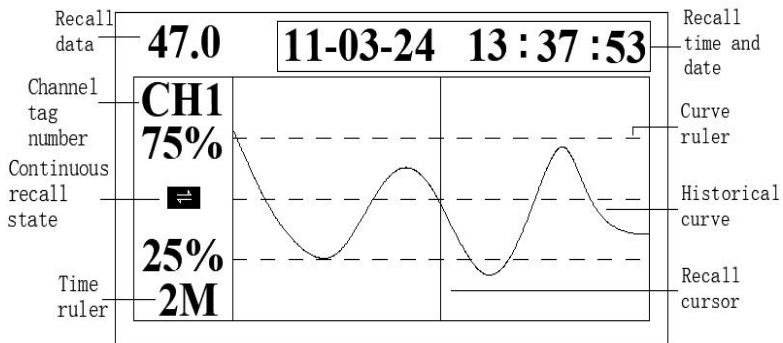

① Recall data: the instrument records the channel display value

corresponding to the current recall time and date.

② The project tag number corresponding to the channel is displayed, where ch1 represents the first channel, CH2 represents the second channel, and so on. The tag number is fixed and cannot be configured.

③ Time scale: 2m indicates that this is a 2-minute curve segment.

④ Recall cursor: the current recall position. When the cursor is in the continuous recall status flag, press [OK] to hide / display the cursor; Press [up] or [down] to realize continuous and rapid recall of historical curve.

⑤ Fixed point recall: when the cursor is at the recall time and date, press [up] or [down] to adjust the number and then press [OK] to realize fixed point recall.

⑥ Curve ruler: displays the 100 component ruler of the curve, corresponding to the 100 component value on the left side of the historical curve screen. The size of the 100 component is adjustable.

⑦ Operation: press [left] or [right] to move the cursor, and press [up] or [down] to adjust the value or switch the selection. Press [OK] to execute the recall cursor display and hidden operation at the continuous recall state where the cursor is located or the fixed-point recall operation at the recall time where the cursor is located. Press [menu] to switch to the print screen (if the print function is not enabled, switch to the alarm list screen).

4.5 POWER DOWN LIST

- ① Serial number: the records are arranged by time. The closer the occurrence time, the later the arrangement. Up to 24 groups of power down / on time information can be saved. A single screen can display up to 3 groups of information at the same time.
- ② Power down / power on time: the upper row is the power down time, and the lower row is the power on time.
- ③ Scroll bar: indicates the position of the current page in the general list.
- ④ Operation: press [up] or [down] to search power down information by page, and press [menu] to switch to the general picture.

No.	Date	Time	
03	22 / 08 / 15	14 : 33 : 33	
	22 / 08 / 15	14 : 47 : 51	
04	22 / 08 / 15	14 : 48 : 14	
	22 / 08 / 15	14 : 48 : 34	
00090/0003240			

Power INF

Scroll bar

4.6 ALARM LIST

	NO.	Date	Time	Alarm type	
Alarm	03	03 / 23	19 : 55 : 03	HH	 Scroll bar
		03 / 23	20 : 27 : 49	CH 4	
INF	04	03 / 23	20 : 38 : 25	HI	
		03 / 23	21 : 41 : 36	CH 3	
	05	03 / 23	23 : 08 : 11	LO	
		03 / 23	23 : 12 : 01	CH 1	Alarm channel

- ① Alarm No.: the records are arranged in time. The closer the occurrence time, the later the arrangement. Up to 24 groups of alarm and alarm cancellation information can be saved. A single screen can display up to 3 groups of information at the same time.
- ② Alarm channel: the channel number that generates the current alarm information.
- ③ Alarm type: the type of current channel alarm, including upper limit alarm HH, upper limit alarm Hi, lower limit alarm lo and lower limit alarm LL.
- ④ Alarm / alarm cancellation time: the upper row is the alarm time, the lower row is the alarm cancellation time, and it is displayed when the alarm is not cancelled--/-- --:--:--。
- ⑤ Scroll bar: indicates the position of the current page in the general list.
- ⑥ Operation: press [up] or [down] to search the alarm information by page

4.7 Input Configuration

In the [configuration] screen, move the cursor to the [input] entrance and press the [confirm] key to enter the [input configuration]. The screen is shown as follows:

Chnl 01	Type 4-20mA
Adj. 0.0	Unit °C
RGE. -99.9	~ 850.0
Rcd. -99.9	~ 850.0
F. 0 S	ALM Exit

- ① Channel serial number: the channel serial number is limited by hardware.
- ② Signal type: it supports signal input of universal analog quantity, such as 4-20mA, 0-20mV, etc. when setting the signal type, it shall be consistent with the signal of primary instrument or detection element.
- ③ Engineering unit: user-defined engineering unit, independent of measurement signal calculation.
- ④ Range: user-defined range, including upper and lower limits, which can be configured freely. When modifying the upper and lower limits of the range, press [OK] to enter the auxiliary interface for quick parameter change.
- ⑤ Decimal places: when in the range setting box, press [menu key] to switch the decimal places.
- ⑥ Linear adjustment: allows the user to adjust the deviation value of the display value. Display data = measurement data + adjustment value, In general, the adjustment value should be set to 0.
- ⑦ Filtering time: the setting of filtering time helps to improve the smoothness of the signal. The longer the filtering time, the smoother the signal but the slower the response.

⑧ Operation: press [left] or [right] to move the cursor, press [up] or [down] to switch the selection or adjustment value, press [OK] to execute the function where the cursor is located or edit the data where the cursor is located, press [menu] to switch the decimal places, and press [exit] to exit the input configuration screen quickly.

■ Alarm configuration

When the cursor stays in the [alarm] button box, press [OK] to enter the secondary alarm configuration interface. The alarm configuration includes parameters such as alarm threshold, alarm contact and alarm return difference. The parameter description is as follows:

HH:	100.0	REL:	Nu
HI:	100.0	REL:	Nu
LO:	0.0	REL:	Nu
LL:	0.0	REL:	Nu
De la:	0.0%		Exit

① Alarm threshold value: the threshold value generated by the alarm must be within the channel range. The alarm signal will be generated or eliminated only when the actual data exceeds the sum or difference of the corresponding limit value and the return difference. The instrument is divided into four categories: upper limit (Hh), upper limit (HI), lower limit (LO) and lower limit (LL).

② Alarm contact: relay number, for example, contact 01 represents relay 01. When the signal value exceeds the alarm set value, the relay corresponding to the contact number will act and the contact will close. If "None" is selected, it means that the relay will not act regardless of

whether the signal exceeds the limit, but there are still alarm records in the alarm list.

③ Alarm return difference: when the signal oscillates near the alarm threshold value, the relay acts frequently. It can set a difference (lag) between the occurrence value and the release value of the alarm. For example, the set range is 0-100, the high alarm point is 80, the low alarm point is 20, and the set alarm return difference is 5.0%. After the high alarm occurs, the instrument will cancel the alarm when the measured value is less than $80 - 100 * 5\% = 75$. Similarly, After the low alarm occurs, the alarm is canceled when the measured value of the instrument is greater than $20 + 100 * 5\% = 25$.

4.8 Output Configuration

In the [configuration] screen, move the cursor to the [output] entrance and press the [confirm] key to enter the [output configuration]. The screen is shown as follows:

Chnl	04	Type	AO
RES		P	
RGE	0.0	~	100.0
SigSour		CH1	
			Exit

① Channel serial number: the serial number of the output channel. The number of selectable channels is limited by hardware.

② Output type: the output signal type of the transmission output channel is fixed to the 4-20mA type of AO.

③ Signal source: Specifies the source sampling channel of the output value of the current transmission output channel.

④ Positive and negative effects: when the analog output (AO) is in the positive effect and the default transmission range is set, the upper limit of the transmission range corresponds to the upper limit of the output current, and the lower limit of the transmission range corresponds to the lower limit of the output current; Under the reaction, the upper limit of the transmission range corresponds to the lower limit of the output current, and the lower limit of the transmission range corresponds to the upper limit of the output current.

⑤ Upper and lower limits of source range: user-defined, upper and lower limits of transmission output range of signal source channel [sampling channel]. To modify the upper and lower limits of the source range, press [OK] to enter the auxiliary interface for quick parameter change.

⑥ Operation: press [left] or [right] to move the cursor, press [up] or [down] to adjust the value or switch the selection, press [OK] to execute the function where the cursor is located or edit the data where the cursor is located, and press [exit] to exit the output configuration screen quickly.

4.9 COMMUNICATION CONFIGURATION

Mode	PC	Add	001
Stop	2 Bit	CKS	Odd
Baud	19200		
<hr/>			
Exit			

Mode	Printf	Add	01
Baud	1200		
<hr/>			
Exit			

■ Communication Configuration

The instrument supports communication and operation with the upper computer to achieve real-time monitoring of the instrument.

- ① Online mode: including PC and printer , To enter the printing configuration, the online mode must be set to the printer before it can take effect.
- ② Online address: the communication online address is used to distinguish the instrument when it forms a network. It is the identification of the instrument in the network. The upper computer software accesses the instrument; The local address in the same communication network can be set between 001 and 255 and cannot be repeated.
- ③ Baud rate: the baud rate cannot be changed when the communication mode is "printer" mode, and the baud rate is optional when the communication mode is "PC" mode (1200、4800、9600、19200、38400、57600) .
- ④ Verification method: no verification / odd verification / even verification. The default is odd verification.The [printer] mode cannot be changed.
- ⑤ Stop bit: 2 bits / 1 bit, 2 bits by default.The [printer] mode cannot be changed.

■ Communication wiring

RS-485 connection mode

The communication line shall be shielded twisted pair (the communication length shall not exceed 1000m). One end of the communication line shall be connected to the serial communication port of the computer through the RS-232 / 485 conversion module, and the other end shall be connected to the 485 communication terminal of the instrument. The connection method is shown as follows.

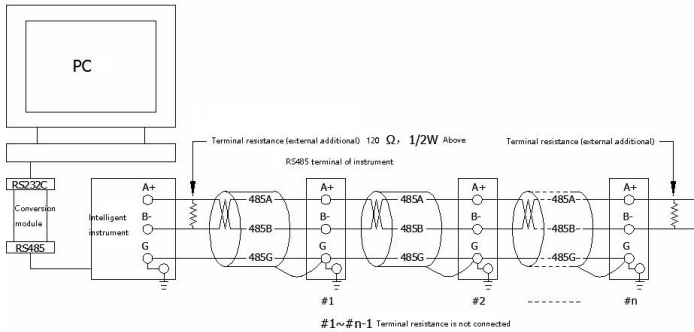

RS-232C connection mode

The user only needs to connect one end of the equipped RS-232C communication line to the interface of the instrument RS-232C and the other end to the serial port of the portable computer (or PDA) to realize the RS-232C communication connection. The communication line shall be made of shielded twisted pair, and the length of the communication line shall not exceed 10m.

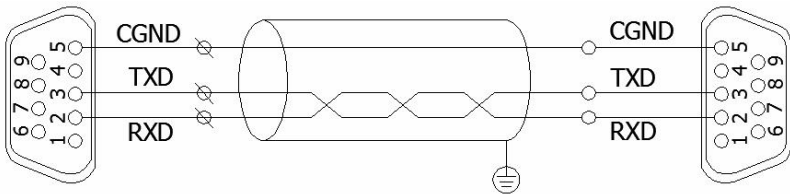

RS232C communication interface at Instrument side

Computer side RS232C communication Interface

4.10 DATA BACKUP

Chnl	01 -04	FAC:	Off
Star	22-08-15	15:27:57	
End	22-08-15	15:27:57	
File	0815152.BIN	BCK	
<input type="text"/>			Exit

- ① Backup channel: the number of channels to be backed up. 01-01 indicates that only the first channel is backed up, and 01-04 indicates that the first channel is backed up 1-4 channels need to be backed up.
- ② Equipment status: displays the status of the U disk, including online, offline and error status. If the U disk is not detected, it displays [offline], and if there is an error during backup, it displays [error].
- ③ Start / end time: start time < end time < current clock time of the system.
- ④ File name: the file name of the backup file. It cannot be changed and is automatically generated by the system.
- ⑤ Progress bar: displays the progress of the current backup process.
- ⑥ Backup / reset / completion button: Backup start / reset button and backup completion prompt button.
- ⑦ Operation: press the [left and right] key to move the cursor, press the [up and down] key to adjust data or switch selection, press the [confirm] key to execute the function of the cursor, and press the [menu] key to switch to the power down list screen.

Note: When the cursor is in the [start] or [End] time setting box, press [OK] to quickly jump.

If there is an error in the process or the copying needs to be restarted, you can stop the cursor at the [backup] button, press the [up and down] key to select [reset], and press the [OK] key to re detect the storage device and then operate.

五、PARAMETER SETTING AND AUXILIARY SCREEN

5.1 CONFIGURATION AND SYSTEM CONFIGURATION

Pass: 00 00 00*	Time 22-08-15 15:50:07
System Input	Pass 00 00 00
Output Exit	BK 1 S Com-Set
	SCRN 0 S SysMaint
	Cold 28 °C Exit

Configuration
screen

System
configuration

■ Configuration

- ① Press and hold [exit] and [menu] for more than one second at the same time to enter the "configuration" entrance. Press [exit] to return to the general picture. Press [direction] to switch the cursor between sub configurations.
- ② The initial password of "configuration" is 00 00 00. After inputting the correct password, press [OK] to enter the hierarchical menu, and then select the corresponding sub configuration entry for configuration setting. If "*" does not disappear, it means that the password is wrong or not confirmed. If the password is wrong, you cannot enter the configuration screen.
- ③ The "configuration" adopts a hierarchical menu structure and has the functions of configuration login password input, system configuration, input configuration, output configuration and exit configuration.
- ④ Operation: press [left] or [right] to move the cursor, press [OK] to execute the function where the cursor is located, and press [exit] to exit the configuration screen quickly.

■ System configuration

In the [configuration] screen, move the cursor to the [system] entrance and press [confirm] to enter [system configuration]. The screen is described as follows:

- ① Time setting: set the system date and time of the instrument.
- ② User password: set the password of user management configuration permission.
- ③ Recording interval: can be set to 1 / 2 / 4 / 8 / 12 / 24 / 36 / 60 / 120 / 180 / 240 seconds. The larger the recording interval, the longer the recording time; conversely, the smaller the recording interval, the shorter the recording time. In general, when the measured signal changes rapidly, the recording interval should be smaller. On the contrary, when the measured signal changes slowly, the recording interval can be larger.
- ④ Cycle switching: used for cycle switching between channels in real-time / historical trend, digital display, etc. the initial value is 0s, which means no cycle switching. Press [OK] to enter the auxiliary interface for quick parameter change.
- ⑤ Cold end compensation: including setting and external modes. When the cursor stays at [cold end], press [OK] to enter the configuration of [cold end setting] to select two modes. In [setting] mode, the cold end fixed value is compensated, and the set value is adjustable. In [external] mode, the system automatically captures the cold end temperature, and the factory default is [external] mode.
- ⑥ System maintenance: [clear power down list] or [clear alarm list] or [restore default settings] and other system maintenance functions. Once the system maintenance is confirmed, the relevant data will be cleared or the factory settings will be restored. The process is irreversible. Please operate with caution.
- ⑦ Operation: press [left] or [right] to move the cursor, press [up] or [down] to switch the selection or adjust the value, press [OK] to execute the function where the cursor is located or edit the data where the cursor

is located, and press [exit] to quickly exit the system configuration.

Note: The user password is the only password to enter the configuration modification parameters. If it is lost, it cannot enter the configuration modification parameters,

The user shall change the password as soon as possible after purchasing the instrument and keep it properly. If it is unfortunately lost, please contact the supplier or our company in time.

Factory settings will initialize all configuration information and clear all stored data in the instrument, including historical data, power down list, alarm list, etc. Please operate with caution

5.2 AUXILIARY INTERFACE

<input type="text" value="5.873"/>	<input type="text" value="5186"/>
Rang : 0.000 ~ 9.999	Error! Out of parameter rang
OK cancel	OK cancel

Auxiliary interface

Some parameters can be entered into the auxiliary interface for quick editing. The auxiliary interface is shown in the figure above. The auxiliary interface is mainly used for setting the upper and lower limits of the alarm and the upper and lower limits of the range. Entering the auxiliary interface (when in the corresponding parameter setting box, press [OK] to enter the auxiliary interface) can quickly adjust the multi bit value. Once the set value exceeds the settable range, Refer to "keyboard function" for key operation.

六、Instrument Structure and Maintenance and Service Guidelines

6.1 Structural characteristics

The structure of the instrument consists of a shell and a movement, which includes an origami mechanism, a paper feeding deceleration mechanism, and a heat printing mechanism. In order to facilitate the replacement of recording paper, the paper folding mechanism is designed in a form that can be shaken out. When replacing the recording paper, press down on the positioning piece and the folding mechanism will automatically pop up.

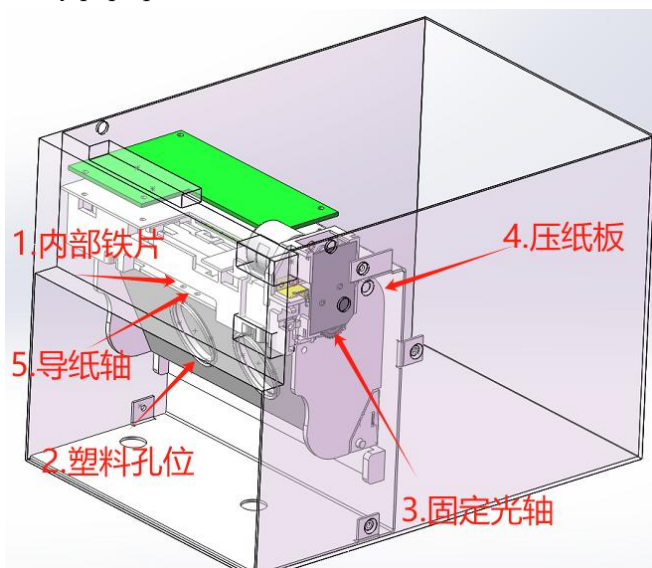

6.1.1 Paper changing method

- ① Press the iron plate above the paper compartment box to remove it* Do not bump the paper bin box
- ② Move the cardboard to the outside by hand and place it in a stack of paper.
- ③ Pull out one end of the paper and fold it a few times, wrap it outside, and insert it under the paper guide shaft to evenly guide the

paper downwards and fold it naturally* At this point, the hot printing surface of the paper should face upwards

- ④ To install the paper bin box, you need to pinch the hole on the top of the box with your hand. The fixed optical axis is parallel to the internal hook shaped structure. When you push it up, there will be a "pop" sound, indicating successful installation.
- ⑤ When a stack of paper is used up, simply remove the paper.
- ⑥ Repeat the above process every time the recording paper is replaced.
- ⑦ When the replacement of the recording paper is completed and the folding mechanism cannot be pushed into the correct position of the movement, press the [Paper] button, and the folding will slowly be pushed in. Remember not to use force forcefully to avoid damaging the gears.

Note: "*" indicates a reminder to pay attention

6.2 Instrument maintenance

- ① The daily maintenance of this instrument is relatively small.
Generally speaking, as long as the hot printing head is kept clean, please take out the printed recording paper in a timely manner to avoid the paper getting stuck in the rubber roller and guide paper bead due to high stacking height, which may affect the service life of the instrument.
- ② Sometimes foreign debris may stick to the heat printing head, causing the heat printing record to fade and a bright strip to appear on the recording paper. When this phenomenon occurs, the heat printing head needs to be cleaned.
- ③ Cleaning method: Take out the origami mechanism, wipe it with a clean wet towel, soft cloth, or cotton dipped in alcohol, and gently wipe back and forth along the length direction of the hot printing head to remove any dirt.

6.3 SERVICE GUIDE

Dear user

Hello!

Thank you for choosing this series of paper recording instruments. Our company will thank you for your trust in our company with high-quality service.

We suggest that you carefully read the "Warranty Principles" section before first use, as this step will facilitate your use of this series of intelligent instruments and understand the warranty services available.

When using this series of intelligent instruments for the first time, first check whether the actual configuration of the product is consistent with the instrument configuration sheet, and whether the accompanying materials and accessories are complete. If you have any objections, please contact us first

① Reading random materials: Please carefully read the random materials and warranty principles, and store them completely.

② After purchasing the machine, keep the purchase invoice properly and fill out the following form carefully so that you can enjoy the corresponding services.

Warranty principles:

① Repair cycle: Five working days from the date of receipt of the product.

② Maintenance costs:

① The free warranty period for this series of intelligent instruments is one year (product quality issues).

② The warranty period is calculated from the date of purchase by the user, and is evidenced by the user's purchase invoice (indicating product model, host serial number) or a copy. If an invoice cannot be provided, it will be calculated from the date of our company's

production.

- ③ During the warranty period, if the product is damaged due to improper use by the customer, or if the customer has opened a qualified product seal, a certain fee will be charged. After the product is repaired, it can be guaranteed for another six months for free.

Customer Notice:

① Please make sure to send the product back with a product fault description to help engineers repair it as soon as possible.

② Please accurately fill in the phone/fax number, mailing address, and contact person for the return of repair items.

③ If you want engineers to go to the site for maintenance, you must bear the costs incurred.

④ The company usually returns it by express delivery (without insurance). If it needs to be transported by another party, please indicate it in the form and pay the relevant fees.

七、 FAULT ANALYSIS AND TROUBLESHOOTING

The paper recorder adopts advanced production technology and undergoes strict testing before leaving the factory, greatly improving the reliability of the instrument. Common faults are generally caused by improper operation or parameter settings. If any unresolved faults are found, please record the fault symptoms and contact us promptly. The following are some fault scenarios and handling measures for this instrument in daily applications:

Fault phenomenon	cause analysis	Handling measures
The instrument is powered on and does not work	1》 Poor contact of the power cord 2》 Power switch not closed	Check the power supply
Signal display does not match recording	1》 Signal type configuration error 2》 wiring error 3》 Input signal error 4》 Incorrect range configuration	1》 Check configuration 2》 Check the signal line 3》 Check signal source 4》 Check configuration
Correct indication, incorrect recording curve	1》 Incorrect configuration of left and right boundaries recorded 2》 Incorrect paper feeding speed configuration	1》 Properly configure recording boundaries and scales 2》 Correctly configuring the paper feeding speed
There is a display, but no heat printing record	1》 Reverse loading of recording paper	1》 Correctly install the recording paper (scratch it with your fingernails, with black scratches on the front side facing upwards)
Display - - - -	1》 Abnormal input signal	1》 Check external signal source input
Abnormal alarm output	1》 Alarm limit configuration error 2》 Alarm contacts are shared by other channels 3》 No alarm contacts set	1》 Reconfigure limit values 2》 Cancel other alarm contacts 3》 Properly configuring alarm contacts

<p>Abnormal alarm output</p>	<p>1 » Wiring error between transmitter and instrument 2 » Multiple transmitters have power supply exceeding the standard distribution of this instrument(power distribution<30mA)</p>	<p>1» Correct wiring 2 » Using an external voltage source for power supply or returning to the factory to customize the maximum load</p>
<p>Unable to communicate</p>	<p>1» The communication cable is not properly connected 2 » Communication parameter setting error 3 » Communication serial port setting error</p>	<p>1 » Connect the communication cable correctly 2 » The communication parameter settings of the recorder and PC are consistent 3 » Set the correct communication COM port (confirm that it is not occupied by other programs)</p>
<p>Transmission output encountered a problem</p>	<p>1 » The transmission output cannot come 2 » The transmission output does not match the actual output</p>	<p>1 » Check if the signal source has been activated 2 » Set the correct transmission range</p>