

FOREWORD

- ⌘ Thank you for purchasing the paperless recorder!
- ⌘ The use's manual contains useful information about the functions of the instrument, installation, wiring, operation procedures, and troubleshooting . To ensure correct use, please read this manual thoroughly before operation.
- ⌘ Keep this manual in a safe place for quick reference in the event a question arises.

Notes

- ⌘ The contents of this manual are subject to change without prior notice as a result of continuing improvements to the instrument's performance and functions.
- ⌘ Every effort has been made in the preparation of this manual to ensure the accuracy of its contents. However, should you have any questions or find any errors, please contact us.
- ⌘ Copying or reproducing all or any part of the contents of this manual without our permission is strictly prohibited.

Revisions

MR71V02C23X

Packing goods

After you open the packing box, please confirm the following before you use it. Please contact our company or sales network once you have received products with incorrect quantity or physical damage in appearance.

No.	Name	Unit	QTY	NOTE
1	Ultra thin wide screen paperless recorder	pcs	1	
2	User Manual	book	1	
3	Mounting bracket (with screws)	pcs	4	
4	Application	set	1	
5	Standard Software (CD)	set	1	
6	U disk	pcs		optional
7	RS232C lines	pcs		optional
8	RS232C/485 convert modula	pcs		optional
9	Micro printer (accessory)	pcs		optional

Matters need attention

- ⌚ If you find that the instrument is damaged by transportation, please contact the manufacturer
- ⌚ This series of instruments is suitable for general industrial occasions. If you have special use requirements, please set up a separate protective device
- ⌚ For the safety of you and the instrument, please do not live installation. Please use the rated voltage power supply, the correct wiring, properly grounded, after the power supply, please do not touch the back of the instrument wiring terminal, in case of electrical shock

- ⌚ The instruments should be installed indoors, and the installation position is to ensure that the ventilation is smooth (in case the temperature inside the instrument is too high), avoid the wind and rain and direct sunlight, do not install in the following situations:
 - An occasion where temperature and humidity exceed the conditions of use
 - An occasion in which a corrosive, flammable or explosive gas is present.
 - Occasions with large amounts of dust, salt and metal powder
 - Occasions where water, oil and chemical liquids are easily spattered
 - An occasion of direct vibration or shock.
 - Electromagnetic source
- ⌚ The instrument should take appropriate shielding measures when it is close to power line, strong electric field, strong magnetic field, static electricity, noise or AC contactor, etc.
- ⌚ In order to avoid measuring error, when the sensor is thermocouple, when the sensor is thermal resistance, use three copper conductors of the same size and resistance value less than 10Ω , otherwise the measurement error will be caused.
- ⌚ In order to extend the service life of the instrument, please carry out regular maintenance and maintenance. Do not repair and disassemble the instrument by yourself. When wiping the instrument, please use a clean soft cloth, do not dip in alcohol, gasoline and other organic solvents cleaning, may cause discoloration or deformation
- ⌚ If the meter has influent, smoke, smell, noise and so on, please immediately cut off the power supply, stop using and get in touch with the supplier or our company in time.

Catalogue

Chapter I Summary.....	6
Chapter II Technical indicator.....	8
Chapter III installation wiring.....	12
3.1 instrument size	12
3.2 pore size	12
3.3 instrument installation	13
3.4 instrument wiring	14
3.4.1 wiring method	14
3.4.2 Terminal description.....	16
3.4.3 Terminal schematic wiring diagram	17
3.4.4 AC / DC input wiring	17
3.4.5 input signal wiring	18
3.4.6 Relay contact output wiring.....	18
3.4.7 transmitter wiring.....	19
3.4.8 communication line.....	20
Chapter IV basic operation and running picture.....	21
4.1 instrument keystroke	21
4.2 usage pattern	22
4.3 status flag	24
4.4 overall picture	25
4.5 Bar picture.	28
4.6 Real-time curve	30
4.7 Historical curve	32
4.8 PID screen	34
4.9 list of power outages	35
4.10 list of power outages	36

Chapter V configuration and Auxiliary Operations	38
5.1 configuration landing.....	38
5.2 configuration screen.....	39
5.3 system configuration.....	40
5.4 Input Configuration	42
5.5 output configuration	47
5.6 Communications configuration	48
5.7 printconfiguration	49
5.8 backup configuration	50
5.9 display configuration	52
5.10 control configuration.....	53
5.11 report queries	55
5.12 functional information	56
5.13 Note and Auxiliary Interface.	58
Chapter VI Fault Analysis and troubleshooting	59
Chapter VII service guide.....	62
Appendix I digit configuration	64
Appendix II Flow Calculation Formula and Instrument Coefficients.....	67
Appendix III types of compensation and commonly used gas density	69
Appendix IV example of traffic usage	72
Appendix V Application of pid control loop.....	74

Chapter I Summary

🕒 Summary

In recent years, some industrial sites have been constrained by installation depth, number of data collection paths and operating comfort, and the general traditional products have completely failed to meet the requirements of the field, which has brought considerable inconvenience to the field application of the instrument unit. Therefore, a short thickness, high integration, rich color, comfortable operation, complete function, high reliability and ideal price performance has great practical significance. The super thin wide screen paperless recorder developed by our company aims to meet the rational demand of the instrument unit and to enhance the perceptual experience of the instrument unit. It is mainly used in petroleum, petrochemical, chemical industry, paper making and plastics, textile printing and dyeing, metallurgical building materials, science and technology Teach national defense, biomedicine, municipal environmental protection, energy metering, food and oil, alcohol and tobacco, equipment manufacturing, equipment sets, agriculture, forestry, animal husbandry, fishery and other industries.

🕒 Function

- Can support touch function (additional function).
- Can support dual communication function (additional function).
- Can support the timing printing function (additional function).
- Can support DC power supply (additional functions).
- Can support Ethernet communication function (custom function).
- Can support vacuum operation function (custom function).
- Can support the communication collection function (custom function).
- Can support feed output function (optional function).
- It can support the output function (selection function).
- Can support alarm output function (optional function).
- Can support pid control function (optional function).

- Can support standard serial communication and printing function (optional function).
- Can support the flow accumulation temperature and pressure compensation function (optional function).
- Data record / transfer backup function (standard function).
- Universal analog input (standard matching function).

Chapter II Technical indicators

🕒 Show

Screen: 7-inch true-color TFT LCD (800*480 dot matrix)

Accuracy: real time display: $\pm 0.2\%$ F.S.

Recall accuracy: $\pm 0.2\%$ F.S.

(note: thermocouple should remove cold end error)

🕒 Processor

High performance arm Cortex-M3 32 bit RISC core can be used to collect, record, display and alarm multiple signals at the same time.

🕒 Memory module

Large capacity parallel NAND FLASH flash chips are used to store historical data, and serial FRAM storage chips are used to store key parameters such as configuration parameters.

🕒 Input function

Input specification: fully isolated universal input, maximum support 16 analog input

Voltage input: 0-5V, 1-5V, 0-20mV, 0-100mV

Current input: 0-10mA, 4-20mA, 0-20mA

Resistor input: Res (0 ~ 400 Ω)

Thermal resistance: PT100, Cu50, G53, Cu100, BA1, BA2 (three-wire resistance balance, lead resistance < 10 Ω)

Thermocouple: S, B, K, T, R, E, N, J

Radiation pyrometer: F1, F2

Tungsten rhenium: WRe3-25, WRe5-26

Attention

Other input signals (such as switch input (DI), pulse input (Pi) or indexing (e.g. PT1000) need to be indicated when ordering

🕒 **output function**

Distribution output: up to 3 sets of transmitters are supported for isolated distribution 24VDC, each group of distribution $\leq 60\text{mA}$, support other specifications of isolated distribution (e.g. 12VDC,5VDC distribution output)

Transmission output: support up to 4 channels standard current output, load capacity $750\ \Omega$ (maximum), convenient display instrument or DCS / PLC acquisition, achieve long distance signal transmission

Relay alarm output: up to 6 relay alarm output, contact capacity $1\text{A}@250\text{VAC}$ / $1\text{A}@30\text{VDC}$ (maximum contact capacity customizable), can be configured upper limit, lower limit alarm.

🕒 **Communication printing**

Communication interface: providing RS232C and RS485 communication interfaces for users to choose from, supporting the use of RS232C and RS485 at the same time, supporting the use of RS232C and RS232C at the same time, supporting Modbus RTU protocol, baud rates-
---(1200,4800,9600,19200,38400,57600)

Print interface: RS232C direct connection to micro printer, baud rate 1200

🕒 **Recording function**

Recording capacity: 64/128/192/248MB (flash capacity optional);

Recording interval: 1 to 240 seconds, divided into 11 files:
1,2,4,4,8,12,24,36,60,120,180,240 seconds.

Recording time: the length of recording time is related to flash memory capacity, input points, and recording intervals. The formula is as follows (the unit in which the value is substituted is consistent with the formula):

$$\text{Record days} = \frac{\text{FLASH volume(MB)} * 1024 * 1024 * \text{interrecord gap(second)}}{\text{Number of channels} * 16 * 24 * 3600} \text{ (Day)}$$

⌚ **Data transfer**

Data backup and storage: support USB 1.1 USB 2.0 USB disk, support 1G to 32GB U disk for data transfer, strong compatibility, compatible with most of the U disk on the market (industrial version recommended)

⌚ **Power Supply Voltage**

Power supply: 100~240VAC (rated 220VAC), 50 / 60HZ AC power supply, 24VDC (18VDC-36VDC) DC power supply, 12VDC (9VDC-18VDC) DC power supply (DC power supply to be indicated when ordering)

⌚ **defensive function**

Power off protection: built-in memory protection parameters and historical data, permanent storage after power off

Clock protection: integrated hardware clock, can also run accurately after power down

⌚ **Error precision**

Compensation error at cold end of thermocouple: ± 2 °C

Clock error: ± 2 seconds / day

⌚ **Working environment [prohibited from working in flammable, corrosive]**

Working temperature: 0°C~50°C (avoid direct sunlight)

Relative humidity: 0~85%R.H (without condensation)

Altitude: < 2000m (other than special specifications)

⌚ **Transport and storage environment**

Transport and storage temperature: -20°C~60°C (avoid direct sunlight)

Transport and storage humidity: 5~95%R.H (no condensation)

⌚ **Instrument net weight**

Net weight: ≤ 1.5 kg

Attention

·The technical index is the general index of this series instrument, the function configuration please take the material object as the standard.

·If the technical index is inconsistent with the physical instrument , please take the object in kind .

Chapter III installation wiring

3.1 instrument dimensions

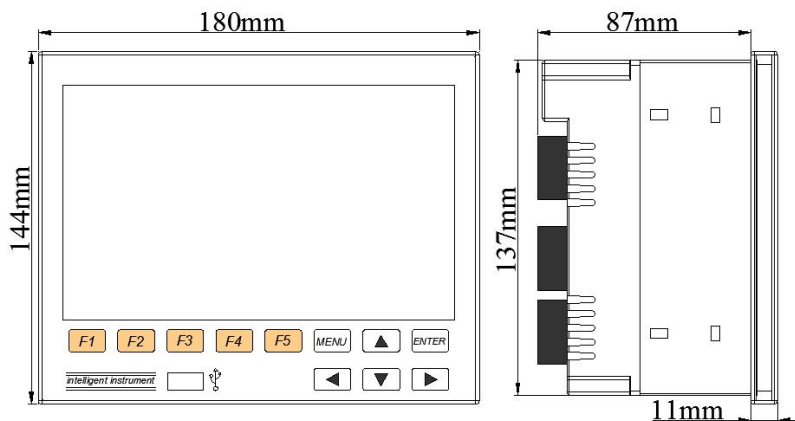

3.2 size of opening

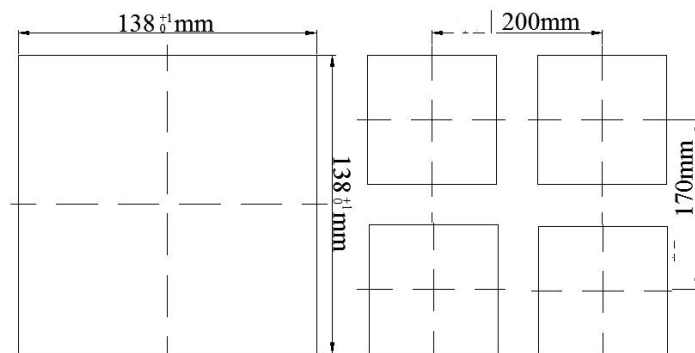

Attention

•When assembling the meter, refer to the minimum spacing between meters recommended in the above table to ensure the necessary heat dissipation and loading and unloading space.

3.3 instrument installation

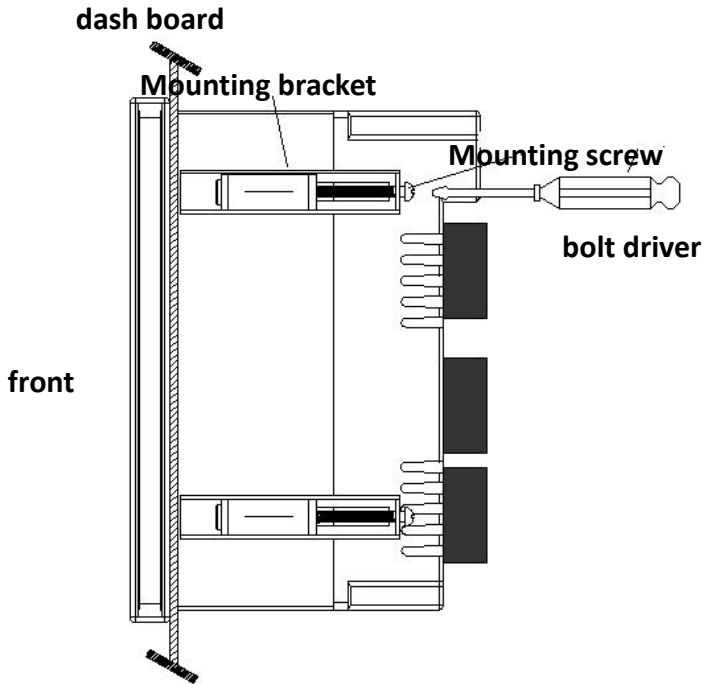

Installation method:

- Step 1: push the meter into the installation hole from the front of the mounting panel (please use the steel plate). The thickness of the mounting panel is (1.5 ~ 4.0) mm.
- Step 2: install the mounting bracket with the instrument as shown above (two supports on both sides of the instrument and M3 standard screw for the instrument panel mounting bracket).
- Step 3: after the meter body is installed, the signal line and power line can be connected.

Attention

- When installing this instrument, please do not tilt left and right, try to install horizontally (can be tilted back $< 30^\circ$).

3.4 instrument wiring

3.4.1 wiring methods

U-type voltage terminal with insulated sleeve (M 3 screw for power supply and signal terminal) is recommended.

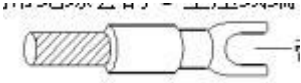

Wire pressing terminal with insulating sleeve

In order to improve the safety of the instrument, please follow the following warning when wiring.



Attention

- To prevent electrical shock, make sure the power supply is cut off before connecting.
- To prevent fire, use double insulated wires (lines with cross sectional area $\geq 0.75\text{mm}^2$; conductors with high voltage resistance and cross section $\geq 0.5\text{mm}^2$) are recommended for relay output wiring.
- Please set the air switch in the power supply loop to separate the table from the total power supply.
- Tighten the terminal screw firmly. Tightening torque: 0.5N.m (5kgf.cm).
- After the power line is connected, the power supply should be connected to check whether the instrument is normal or not. Please do not connect the signal line until it has been confirmed that the instrument can work normally, and then disconnect the power supply and carry on the connection of the signal line.
- The measuring circuit and the power circuit need to be laid separately, the object of measurement should not be an interference source, once it is unavoidable, please insulate the measuring object from the measuring circuit, and grounding the measuring object.
- For electrostatic interference, the use of shielding lines is better.
- For the interference caused by electromagnetic induction, it is better to equip

the measuring circuit with equal distance.

- If the input wiring is connected in parallel with other instruments, the measurement value will be affected. Be careful not to switch off the power supply of one of the instruments when you have to run in parallel. This will have a negative impact on other instruments. The thermal resistance cannot be paralleled in principle, and the current signal can not be parallel in principle.
- When entering thermocouples, please do not use thick lines with good heat dissipation (cross sectional area $< 0.5\text{mm}^2$), and try not to cause external temperature changes (especially if the switches of nearby exhaust fans will cause larger temperature changes). Platinum resistance input should be less than $10\ \Omega$ per lead resistance (lead resistance value is the same).

3.4.2 Terminal description

Terminal name	Explain
L/+,N/-, 	L is the AC power source phase line end,N is the AC power source zero end,  is the ground end, + is the DC power source positive end, - is the DC power supply negative end, when the DC power supply, please indicate when ordering.
Serial communication interface	RS232C communication interface/serial port print interface (where 2 pin are RXD instrument signal receiving terminal,3 pin is TXD instrument signal transmitter terminal ,5 pin is signal ground end)
R1~R6	Relay output port 1A/250VAC@1A/30VDC
485+,485-	Signal transmitter and receiver of RS485 communication interface
P+,P-	24VDC feed output positive, negative, each group \leq 60mA
AO+,AO-	Positive and negative end of analog current output
B,C,D	Sampling signal terminal, specific signal wiring see related wiring diagram

3.4.3 Terminal schematic (whichever is in kind)

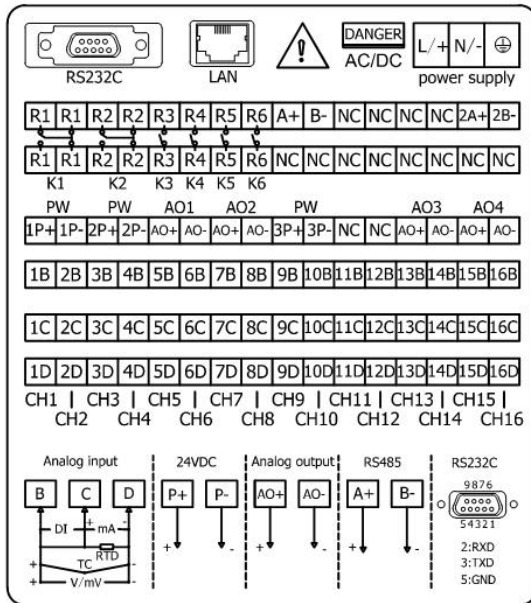

3.4.4 AC/DC input wiring

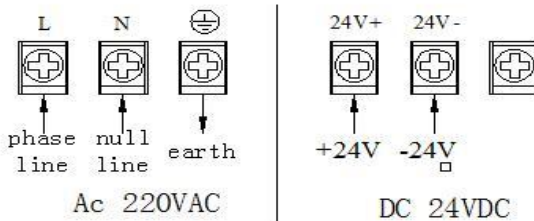

Attention

The power input mode of the project site must be consistent with the power input mode provided by the instrument itself.

The power supply voltage at the project site shall be limited to the withstand voltage range of the instrument.

3.4.5 input / output signal wiring

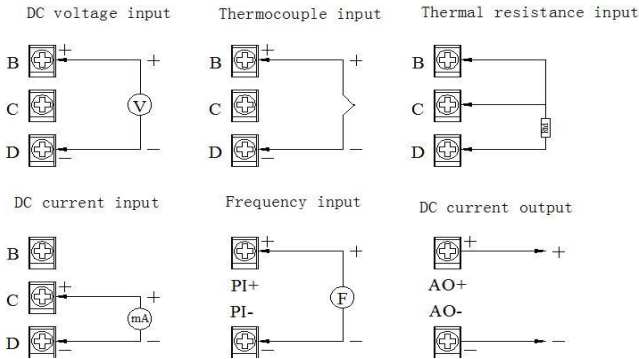

Attention

The switch input should be explained when ordering, once a certain channel input signal is switch quantity signal, the channel will no longer support analog quantity, thermal resistance, thermocouple and so on.

Other signals, such as PT1000, 0-10 V need to be specified when ordering.

3.4.6 Relay contact output wiring

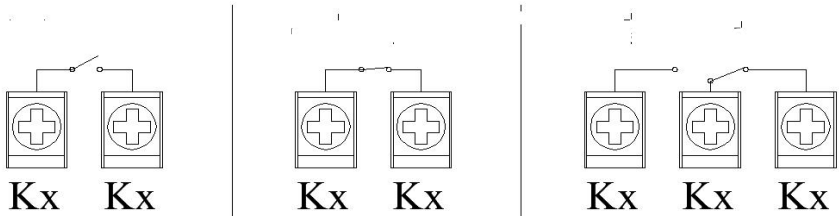

Attention

The cross-sectional area of the wire is $0.5 \sim 2.5 \text{mm}^2$, and the torque is 50Nm. This machine often opens the factory by default, the other way to leave the factory please indicate when ordering.

The default contact capacity of the machine is $1\text{A}@250\text{VAC}/1\text{A}@30\text{VDC}$, and the other higher contact capacity is specified in the order.

3.4.7 transmitter wiring

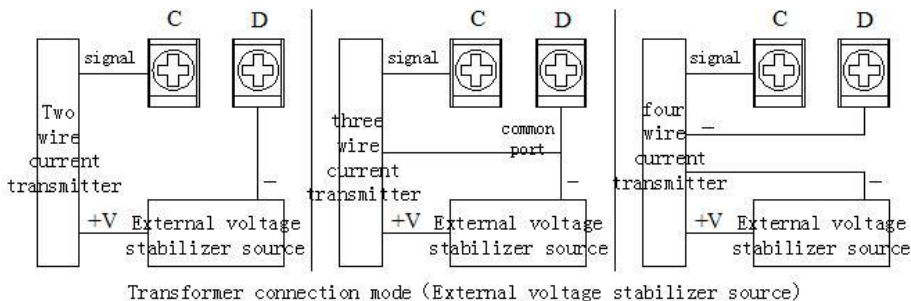
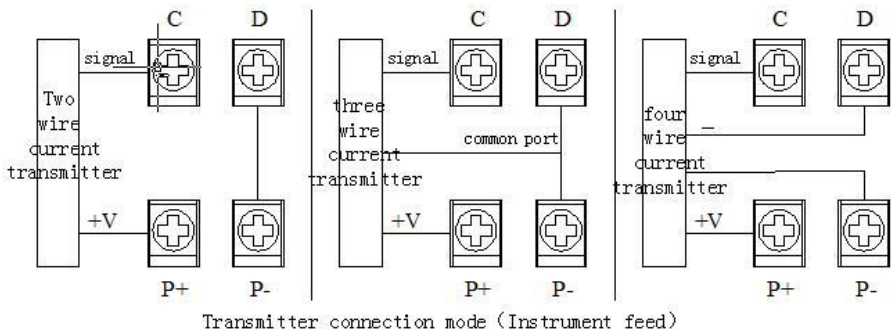

Attention

The default 24VDC feeder factory, other specifications please indicate when ordering.

When the transmitter power consumption exceeds the load capacity of the machine, please use an external voltage regulator.

3.4.8 Communication wiring

RS-485 connection mode

Use shielded twisted pair wire (no more than 1000 meters in length) with one end. The RS-232/485 conversion module is connected to the serial communication port of the computer and the other end to the 485 communication terminal of the instrument.

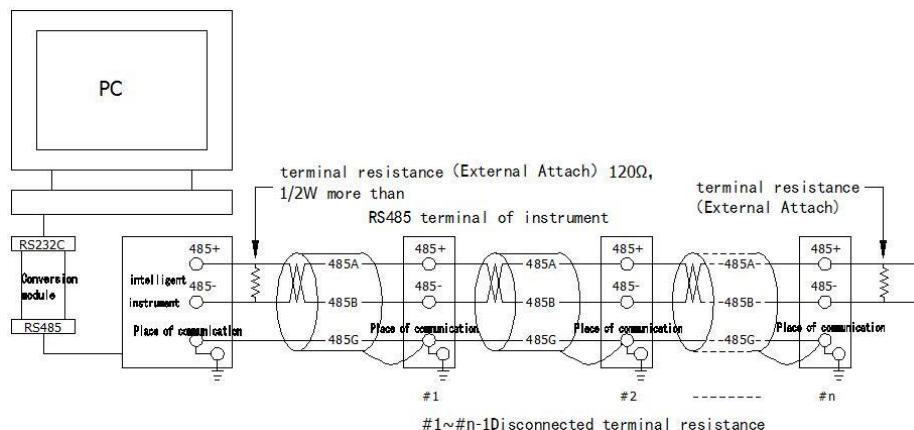

RS-232C connection mode

The user only needs to connect one end of the RS-232C communication line to the instrument RS-232C, the other end is connected to the serial port of the portable computer (or PDA), the RS-232C communication connection can be realized. The communication line should be made of shielded twisted-pair wire, and the length of the communication line should not exceed 10 meters.

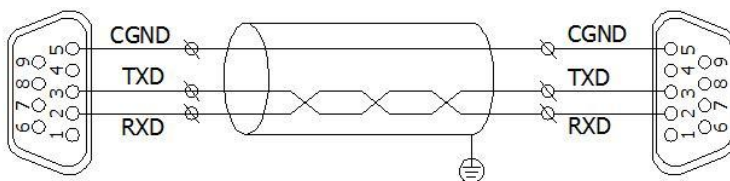

Instrument side RE232 communication interface

Computer side RE232 communication interface



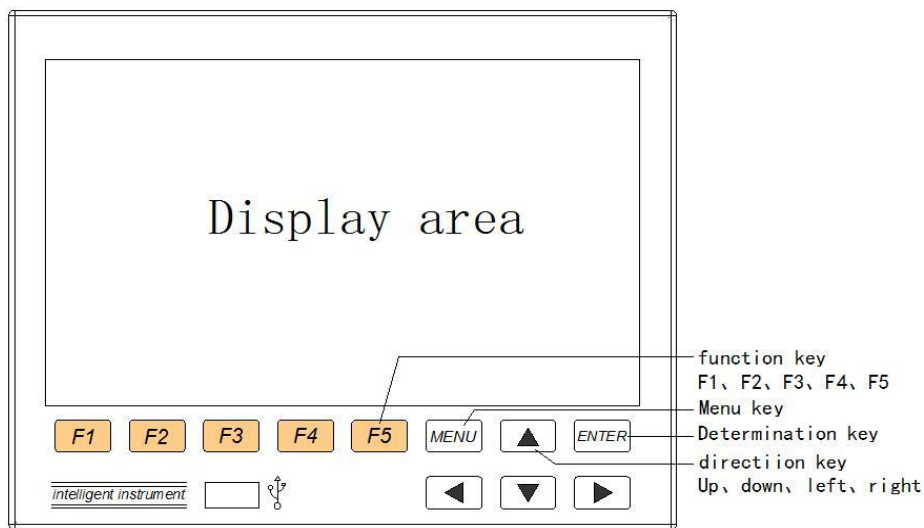

Attention

Chapter IV basic operation and running picture

4.1 instrument keys



🕒 Keyboard function

symbol	name	function
	Menu key	Switch main display pages, etc.
	Left key	Switch channels or move the cursor forward, etc.
	Right key	Switch timescale or move back cursor, etc.
	Upward key	Switch to select or increase cursor data values, etc.
	Down key	Switch to select or reduce cursor values, etc.

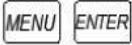
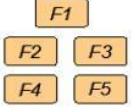
	Confirmation key	Perform cursor location function or edit cursor location data, etc.
	combination key	Hold down more than 1 second at the same time, enter the configuration interface
	function key	Functional operation keys corresponding to soft keys in each screen

4.2 usage patterns

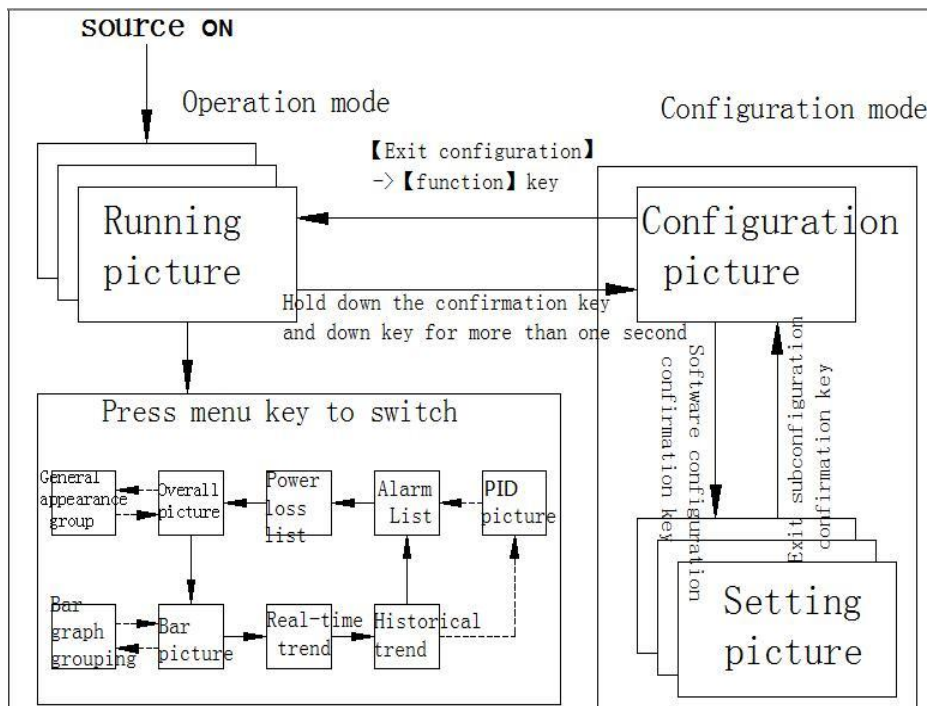

Pattern type	content	Possible operation
Operation mode	Data display , query operation mode	Display test / operation data
	Power on the system goes into this mode	
	Use the [menu key] to switch to the next sub-run screen	
	Operation mode data display, query operation mode Power on the system goes into this mode use the [menu key] to switch to the next sub-run screen simultaneously hold down [menu key] and [confirm key] for 1 second or more and enter configuration login screen	
Configuration mode	Configuration mode for input signal, input range, alarm parameters, etc.	Configuration parameter setting
	Do not display measurement /operation data	

4.3 status markers

Run mode, configuration mode in the state display section displays the following information.



① Title bar: displays the current screen name.

② Circular signs:

- A. have display: cycle switch each display combination.
- B. no display: fixed screen, no cycle switch.

● USB device logo

- A. there is a display: detected USB and meter connection.
- B. no display: no USB and instrument connection.

○ System sound sign

- A. display: allows the system buzzer to make sound while operating the button.
- B. no display: disable the system buzzer from making sound while operating the key.

■ System alarm sign

- A. has the display: the system has the alarm to produce.
- B. no display: system no alarm generated.

□ Data backup sign

- A. there is a display that: USB is backing up the data.
- B. no display: USB is not backing up data.

❑ System print mark

A. have display: micro printer is printing data curve.

B. no display: micro printers do not print data curves.

❑ Storage capacity flag

A. green: shows green when the capacity is between 0% and 80%.

B. yellow: yellow when the capacity is between 80% and 90%.

C. red: displays red when capacity is between 90% and 100%.

❑ System Time Flag : Displays the current system time date for the meter .

4.4 overall appearance and flow picture

The single screen can display the real - time data of 16 channels , and the number of channels is not the same as that of the display . The 6 - channel picture is shown in the following figure , as follows :

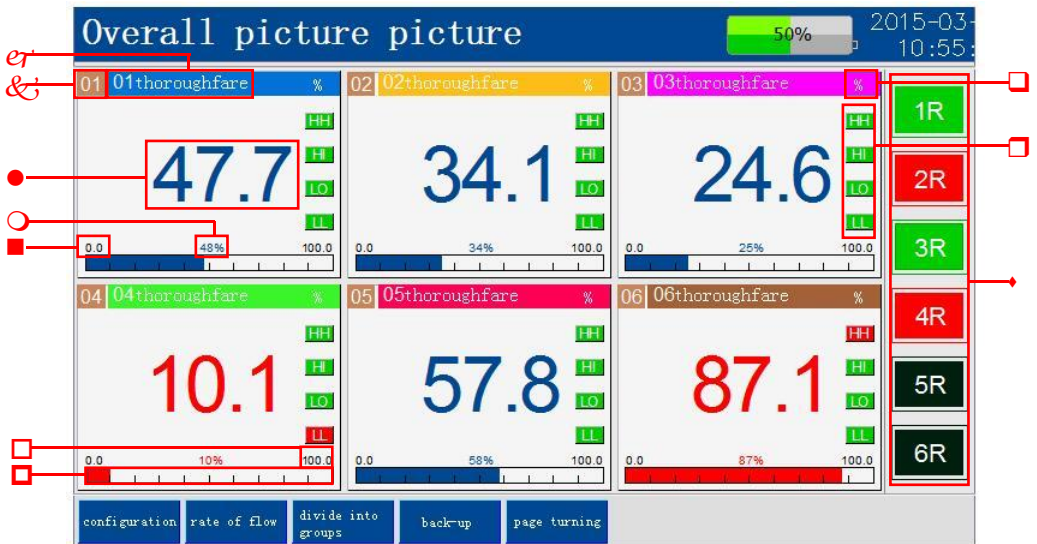

e Channel serial number: shows the channel sequence number corresponding to the channel (8 channel and above channel total appearance and group

picture without this function).

- &Project bit number: show the corresponding project bit number of channel, can be configured freely.
- Real time data: display the engineering quantity measurement/operation data of the channel. If the current channel is in alarm state, the measurement/operation data will turn red.
- Percentage of data: the percentage of current data in the total process.
- Lower range: user defined range, freely configurable.
- Upper limit of range: user defined range, freely configurable.
- ▣Bar diagram: the length of the bar icon ruler is 10 lattice, and the fill area represents the percentage of the current data in the total program. When the system is in alarm, the fill area turns red.
- Unit : the engineering units that display the passage are freely configurable.
- Relay state: display current relay output state, red in alarm state, green for normal state, black for unmatched relay.
- ♦Alarm status: from top to bottom (or from left to right, depending on the number of channels) is the upper limit HH / upper limit / lower limit LOL / lower limit LLL respectively, red means over-limit alarm. When the system is in the alarm state, the status bar appears system alarm sign.
- ①Operations: press [F1] function key to quickly enter the configuration landing screen; Press the [F2] function key to quickly enter the flow monitoring screen (the cursor must first select the relevant channel and the system opens the flow function, when in the flow monitoring screen, press the [F2] function key to switch back to the overall picture, [F1], [F4], [F5] the function of function key is the same as the general picture.) Press [F3] function key to enter the grouping screen (need to set up the corresponding display combination first, the display combination can be freely configured in [display configuration] (maximum support for 6 groups of display combinations, Each group supports 8 channels), which can be displayed by [F1], [F2] function key switching combination, [F3] function key can be switched back to the overall appearance picture, [F4], [F5] function key function same as the overall appearance

picture, The grouping picture shows that the combination can switch automatically and the loop automatic switch function can be configured freely in system configuration. If the system does not set a display combination, there is no grouping function key);

Press the " F4 " function key to quickly enter the standby backup configuration screen for data backup (need to be decrypted before decryption , and jump directly to the standby backup configuration screen after decryption) ;

Switch to the bar chart screen by pressing the " F5 " function key or the menu key of the menu .

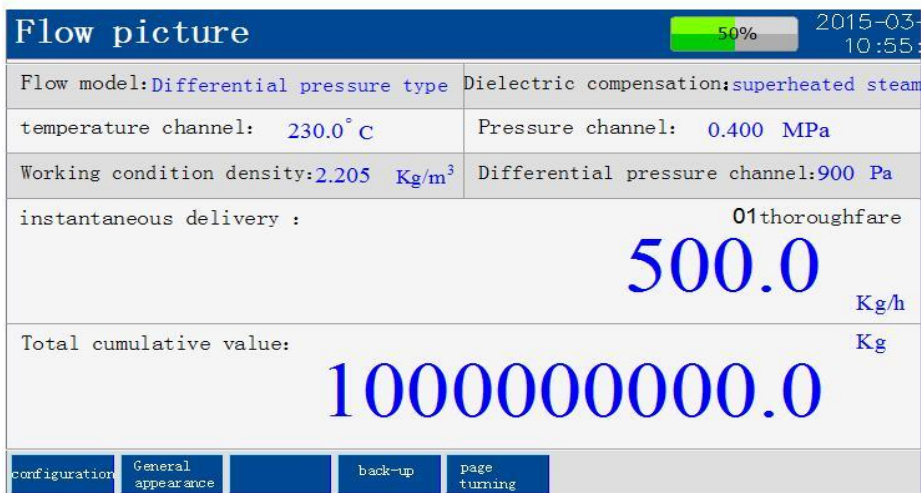

⑪ Instantaneous flow: the instantaneous flow calculation value of the current channel.

⑫ Total cumulative value: the total cumulative flow value of the current channel.

4.5 Bar Chart Screen

The single screen can display 16 channels of data bar chart , and the number of channels is not the same as that of the display . The data bar chart of 6 channels is shown in the following figure , as follows :

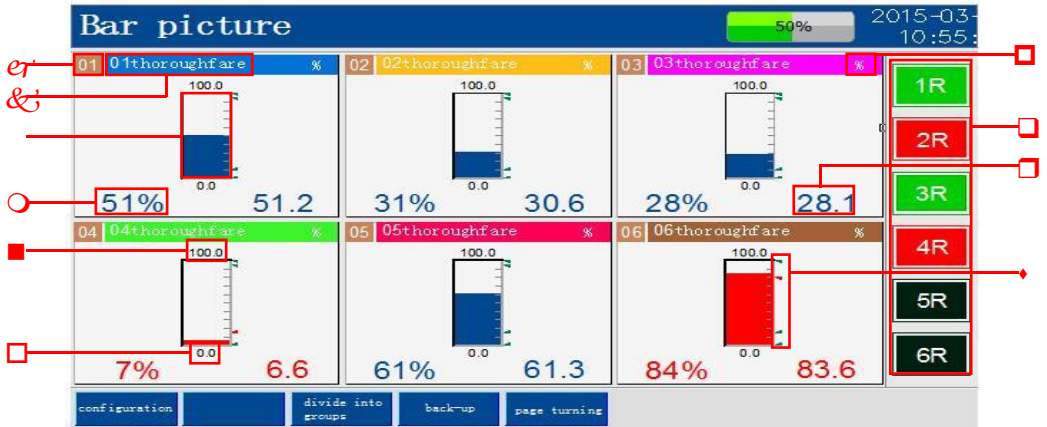

e Channel serial number: shows the channel serial number corresponding to the channel (8 channels and above channel bar diagram and group picture do not have this function).

& Project bit number: show the corresponding project bit number of channel, can be configured freely.

● Bar diagram: the length of bar icon ruler is 10 lattice, the bar graph fill area represents the percentage of the current data in the total program, when the system is in alarm, the fill area becomes red.

○ Percentage of data: the percentage of current data in the total process.

■ Upper limit of range: user defined range, freely configurable.

□ Range lower limit: user defined range, freely configurable.

□ Unit : the engineering unit that displays the passage is freely configurable.

□ Relay state: show current relay output state, red in alarm state, green for normal state, black for unmatched relay.

□ Real time data: display the engineering quantity measurement/operation data

of this channel, if the current channel is in alarm state, the measurement/operation data will turn red.

- ◆ Alarm status: From upper to lower is upper limit HH/upper limit HI/lower limit LO/lower limit LL, red indicates overlimit alarm. When the system is in the alarm state, the state bar appears system alarm sign.

11 Operations: press [F1] function key to quickly enter the configuration landing screen;

Press [F3] function key to enter the grouping screen (the corresponding display combination must be set first, display combinations are freely configurable in display configuration (maximum support for 6 groups of display combinations, each group supports 8 channels), the function key [F1], [F2] can be pressed on the grouping screen, toggle the combination display, Press the [F3] function key to switch back to the bar graph [F4]、[F5] the function key function is the same stick picture, the grouping picture display may cycle the automatic switch, loop automatic switching function can be freely configured in system configuration. If the system does not set an explicit. if the combination is shown, there is no grouping function key);

Press the [F4] function key to quickly enter the backup configuration screen for data backup permission decryption, decryption directly to the [backup configuration] screen);

Press the F5 function key or [menu key] to switch to a real-time curve screen.

4.6 Real-time curves

A single screen can display a maximum of 8 channels of real-time curves and data, of which 6 channels are described as follows:

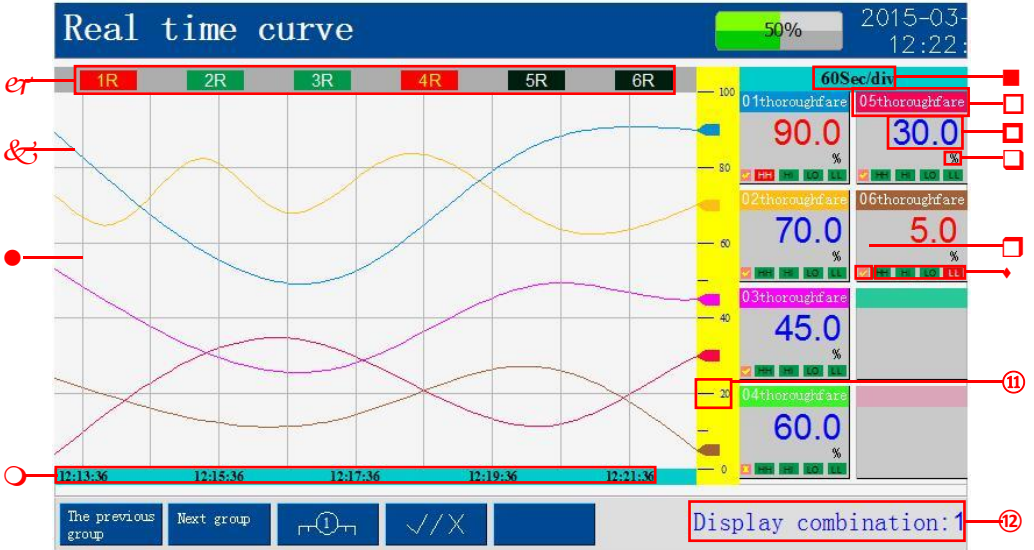

er Relay Status : Displays the current relay output status , the red is in the alarm state , the green represents the normal state , and the black representative does not match the corresponding relay .

& Real-time curve: the display value of the current measurement / operation data corresponds to the right end of the curve.

● Grid: easy for users to estimate time and data values.

○ Grid time: the time represented by the current grid.

■ Time scale: the length of time represented by each grid, depending on the recording interval, performing function equivalent to [F 3] function key operation.

□ digit number: show the corresponding project bit number / channel serial number of channel, can be configured freely.

□ Real time data: display the engineering quantity measurement / operation

data of the channel, if the current channel is in the alarm state, the measurement / operation data will turn red.

- Unit: the engineering units that display the passage are freely configurable.
- Display / hide sign: "squared" display curve, " × " hidden curve, performing function equivalent to [F4] function key operation.
- ♦ alarm status: from left to right is upper limit HH / upper / lower limit LOL / lower limit LLL, green for normal state, red for over-limit alarm.
- ⑪ Curve scale: a 100-component scale showing the curve.
- ⑫ Display combination: current display combination number, freely configurable. When all combinations are not configured, the instrument will be combined in channel order, 8 channels per group. Display combination can cycle automatic switch, cycle automatic switching function can be freely configured in the system configuration.
- ⑬ Operation: switch up or down [F1] or [F2] to view the remaining composite curve data;
According to [F3] can modify the time scale to switch each screen display data or curve width, according to [F4] display / hide cursor selection channel curve;
Press [F5] or [menu key] to switch to the history curve screen;
Press [to the left] or [to the right] to move the cursor;
Press confirm key to perform the cursor channel curve display / blanking operation.

4.7 Historical curve

A single screen can display up to 8 channels of historical curves and data, of which 6 channels are described as follows:

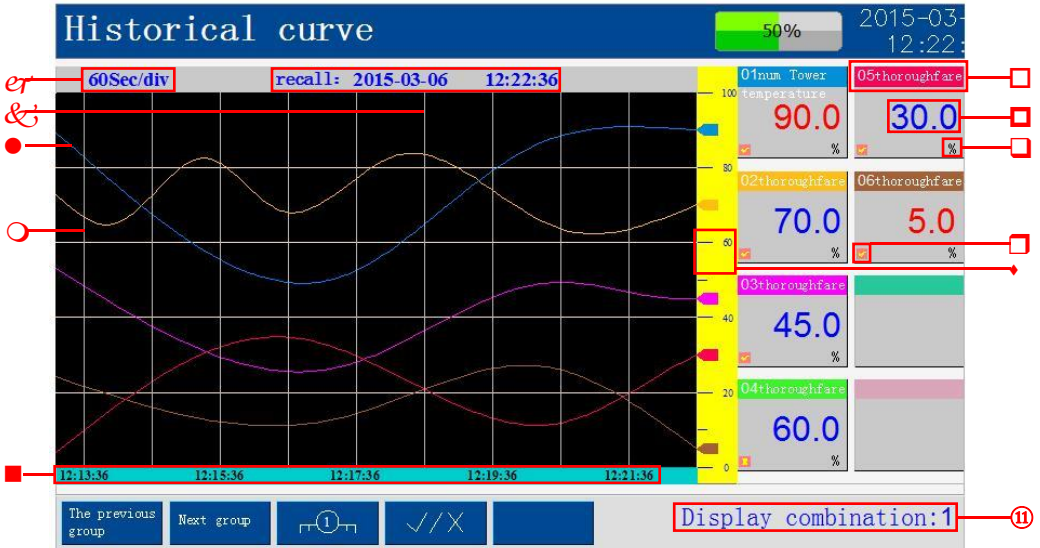

er Time scale: the length of time represented by each grid, depending on the recording interval, performing function equivalent to [F 3] function key operation.

& Recall time: set the corresponding recall time date and press confirm key to recall at fixed point.

● Recall curve: a section of historical curve recorded in multiple grid time, can have its own configuration curve / data color.

○ Grid: easy for users to estimate time and data values.

■ Grid time: the time represented by the current grid.

□ digit number: show the corresponding project bit number / channel serial number of channel, can be configured freely.

□ Recall data: the instrument records the channel display value corresponding to the current recall time.

- ❑ Unit: the engineering units that display the passage are freely configurable.
- ❑ Display / hide sign: "squared" display curve, "×" hidden curve, performing function equivalent to [F4] function key operation.
- ♦ Curve scale: a 100-component scale showing the curve.
- ⑪ Display combination: current display combination number, freely configurable. When all combinations are not configured, the instrument will be combined in channel order, 8 channels per group. Display combination can cycle automatic switch, cycle automatic switching function can be freely configured in the system configuration.
- ⑫ Operation: switch up or down [F1] or [F2] to view the remaining composite curve data;
 - According to [F3] can modify the time scale to switch each screen display data or curve width, according to [F4] display / hide cursor selection channel curve;
 - Switch to the PID screen (if the system does not turn on the PID control function , switch to the alarm list screen) ;
 - Right - click to move the cursor or make continuous pursuit (the cursor needs to be located at the recall location axis) ;
 - Press [up key] or [down key] to adjust the value;
 - Press [confirmation key] to perform the cursors' channel curve display / blanking sign curve display / blanking operation or perform the cursor's recall time point recall operation or execute the cursor's location axis (the cursor is located at the tracing location axis), where the cursor is located, or where the cursor is located. Display / blanking operation of positioning axis after memory time and before display / blanking sign.

4.8 PID screen

As shown below, the single screen displays 1 PID control loop parameters, curves, numerical bar charts, etc. the picture is as follows:

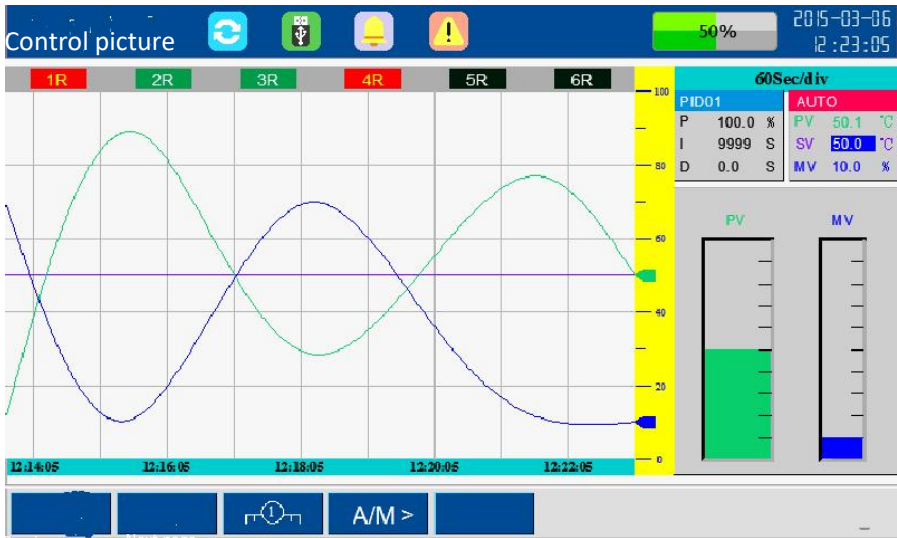

- ① P: the ratio coefficient value, the bigger the value, the weaker the proportion effect.
- ② I: the integral time is zero, otherwise the greater the value, the weaker the integral action.
- ③ D: the differential time is zero, otherwise the greater the value, the stronger the differential action.
- ④ AUTO/ MAN: automatic state / manual state.
- ⑤ PV : Sample value .
- ⑥ V: set a value.
- ⑦ MV: loop output value.
- ⑧ Operations: look at the remaining loop curve data by switching up or down [F1] or [F2];
Press [F3] to modify the time scale to switch the display data or curve width per screen;

- Press [F4] to switch hands automatically;
- Press [to the left] or [to the right] to move the cursor;
- Press [up key] or [down key] to adjust the data;
- Press [confirm key] to edit cursor data;
- Press [menu key] to switch to alarm list screen.

4.9 alarm list

A single screen can display up to 12 alarm messages, the screen is described as follows:

Alarm List						50%	2015-03-12:23
order number	thoroughfare	type	Alarm time		Cancellation time		
▶ 13	CH01	HH	2015-03-05	08:25:06	2015-03-05	08:26:23	1R
14	CH03	LL	2015-03-05	08:30:11	2015-03-05	08:32:16	2R
15	CH06	LO	2015-03-05	08:33:04	2015-03-05	08:35:59	3R
16	CH03	HH	2015-03-05	08:34:02	2015-03-05	08:36:28	4R
17	CH01	HH	2015-03-05	08:43:18	2015-03-05	08:47:53	5R
18	CH06	LL	2015-03-05	09:15:26	2015-03-05	09:16:47	6R
19	CH04	HI	2015-03-05	14:23:44	2015-03-05	14:32:25	
20	CH05	HH	2015-03-05	17:08:39	2015-03-05	18:22:22	
21	CH01	HI	2015-03-06	08:25:06	2015-03-06	08:26:23	
22	CH02	LL	2015-03-06	08:44:35	2015-03-06	08:56:04	
23	CH01	HI	2015-03-06	09:09:09	2015-03-06	09:37:46	
24	CH06	LO	2015-03-06	10:03:48	2015-03-06	10:15:19	

Navigation buttons: Previous page, back page, The last one, Next, configuration

- ▶ Pointer: the mark that points to the search result when a sequence number or page number is retrieved.
- & Serial number: the record is arranged according to the time, the closer the occurrence time, the more the arrangement, can save up to 48 alarm and cancellation information, single screen can display 12 messages at the same time.
- Alarm channel: the channel number that produces the current alarm information.

- Alarm type: current channel alarm type, upper limit alarm HH, upper limit alarm, lower limit alarm LOL, lower limit alarm LL.
- alarm / cancellation time: red is alarm time, blue is cancellation time, unreported It shows 20//--/--// //://://.
- Relay state: display current relay output state, red in alarm state, green for normal state, black for unmatched relay.
- Operation: according to [F1] or [F2] according to page search alarm information;
Press [F3] or [F4] to retrieve alarm information;
Press F 5 or menu key to switch to the power-down list screen.

4.10 list of power outages

A single screen can display up to 12 power loss information, the screen is described as follows:

Power loss list		50%		2015-03-12 12:24	
Number	Power down time		Power-on time		
▶ 01	2015-02-27	11:09:13	2015-02-27	11:17:22	
02	2015-02-27	11:19:26	2015-02-27	12:00:05	
03	2015-02-27	17:09:50	2015-02-28	08:10:33	
04	2015-02-28	11:32:42	2015-02-27	12:07:55	
05	2015-02-28	17:48:09	2015-03-01	08:15:37	
06	2015-03-01	11:36:44	2015-03-01	13:55:16	
07	2015-03-01	18:10:35	2015-03-01	19:28:29	
08	2015-03-01	20:30:53	2015-03-02	10:26:47	
09	2015-03-02	13:33:25	2015-03-02	14:05:08	
10	2015-03-02	15:08:02	2015-03-02	15:10:14	
11	2015-03-02	17:32:17	2015-03-03	08:56:31	
12	2015-03-02	10:24:18	2015-03-03	12:33:28	

Previous page	back page	The last one	Next	configuration
---------------	-----------	--------------	------	---------------

⇨ Pointer: the mark that points to the search result when a sequence number or page number is retrieved.

& Sequence number: the record is arranged in time, the closer the time, the more after the arrangement, the maximum can be saved up to 48 lines of power time information, the single screen can display at most 12 information at the same time.

● Power-down / power-on time: red for power-down time, blue for power-on time.

○ Operation: press [F1] or [F2] to retrieve power loss information;

To retrieve the power loss information according to [F3] or [F4];

Press F 5 or menu key to switch to the overall picture.

Chapter V configuration and Auxiliary Operation

5.1 configuration landing

At the same time, hold down [menu key] and [confirm key]one second later (part of the screen can also press [F1] function key), enter the configuration login screen, select the appropriate operator authority and enter the correct password to enter the configuration screen, Then select the corresponding sub-configuration entry configuration settings, password errors can not enter the configuration screen, the picture description as shown in the figure:

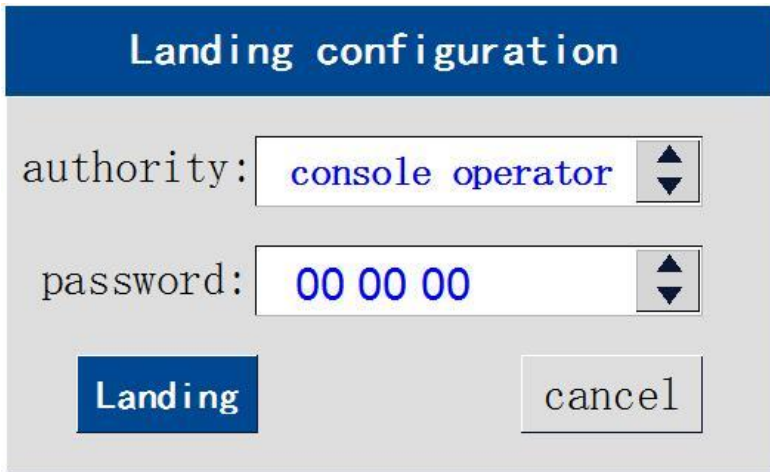

*e*Permission: the operator permission to enter configuration mode, divided into operators and administrators, the permissions are different from the sub-configuration they can enter, operator permissions can only enter the input, backup and print sub-configuration, Administrator permissions can enter any child configuration.

*&*Password: the default initial password for operator permissions is 000 00 00, and the default password for administrator rights is 10 00 00.

- Operation: according to [F4] landing configuration;
Cancel configuration login by [F5];

Press [to the left] or [to the right] to move the cursor;
Press [up key] or [down key] to select or adjust the value;
Press [confirm] key to perform cursor function.

5.2 configuration picture

[login configuration] decrypted into the [configuration screen], the picture description as shown in the figure:

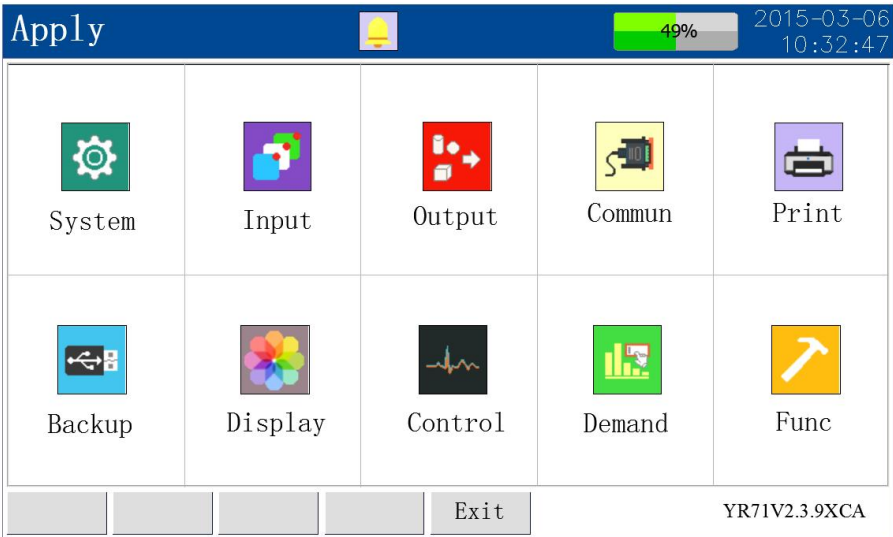

e Configuration: use hierarchical menu structure, with system configuration, input configuration, output configuration, communication configuration, printing configuration, backup configuration, display configuration, control configuration, report inquiry, function information, software version and so on.

& Software version: software version used by the current system.

- Operation: press [F5] to exit configuration screen;
Press [to the left] or [to the right] to move the cursor;
Press [up key] or [down key] to move the cursor;
Press [confirm key] to enter the cursor sub-configuration screen.

5.3 system configuration

Move cursor to [system] entry in [configuration] screen, press confirm key to enter [system configuration], picture description as shown in figure:

Setting	Value
Date	05
Time	14:26:38
Administration password	CH01
Operation password	00 00 00
Interval	CH01
Key Sound	Enable
Auto Switch	0.0
Sys-Maint	Clear Pow Inf
PID Setting	CH01
Language	English
Dev-Alias	0.0

Custom [] [] [] Exit YR71V2.3.9XCA

Time date setting: set system date and time.

Administration password: administrator permissions login configuration to modify or view parameters of the unique password, the initial default 10 00 00.

Operation password: operator login configuration changes or view parameters of the unique password, the initial default of 00 00 00.

Record interval: can be set to 1 / 2 / 4 / 8 / 12 / 24 / 36 / 60 / 120 / 180 / 240 seconds. The larger the recording interval, the longer the recording time, conversely, the smaller the recording interval, the shorter the recording time. In general, when the measured signal changes more quickly, the recording interval should be smaller. On the contrary, when the measured signal changes slowly, the recording interval may be larger.

Keystroke sound: the system allows / disables buzzers during keystroke operation.

- ❑ Auto switch: cycle displays the time period value of each display combination screen.
- ❑ System maintenance: the system maintenance function, such as [clear the power off list] or [clear the alarm list] or [restore the default setting], press [confirm key] to enter the "system maintenance" parameter selection. Once system maintenance is confirmed, the data will be cleared or factory settings will be restored, the process will not be reversible, please operate with caution.
- ❑ PID setting: allow or prohibit PID picture parameter adjustment function, that is, when opening, the parameters in PID picture are allowed to be adjusted, otherwise, it is not allowed.
- ❑ Class: set up the cumulative shift and start time, starting from the setting time of shift 1, according to the order of shift 1, frequency 2, shift 3 and shift 1, ending at the beginning of the next shift 1. For a cycle of 24 hours. The following principles should be followed: shift 1 < shift 2 < shift 3.
- ♦ Operation: press [F5] to exit the system configuration screen quickly;
Press [to the left] or [to the right] to move the cursor;
Press [up key] or [down key] to select or adjust the value;
Press confirm to perform cursor location function or edit cursor location data.

Attention

The operation and management password is the only password that can enter the configuration modification parameter. It is suggested that the user should modify the password as soon as possible after purchasing the instrument and keep it properly.

To change the operator password, log in to the system parameters under the administrator's permission. Operator permissions do not have the permission to change the password.

Factory settings will initialize all configuration information and clear all stored data in the instrument, including historical data, power loss list, alarm list, etc.

5.4 input configuration

In the configuration screen, move the cursor to the input entry, press confirm key to enter the input configuration, the picture description is as shown in the figure:

Label	Value
Chnl Number	01
Signal Type	Sin
Point Num	1
Min Range	0.0
Cut	0.0 %
Stanrd Temp	25 °C
Chnl Name	Chnl 01
Target Unit	°C
Filter Time	0.0 S
Max Range	100.0
Max Range	k:1.00 b:0.0

Flow Alarm Copy Paste Exit

YR71V2.3.9XCA

e Channel serial number / bit number: Channel serial number is limited by hardware, support bit number modification function, bit number modification details see Appendix I [bit number configuration].

& Type of signal: support universal analog input such as 4-20mA, 0-20mV. The signal type should be the same as the signal of the primary instrument or detection element. Press [confirm key] to enter the 'Type selection screen' for quick type selection.

● Engineering unit: user-defined engineering unit, independent of measurement signal calculation, supporting user-defined expansion unit (1), operating the same number modification function Press [confirm key] to enter the 'unit selection screen' for unit selection.

○ Digits: the volume of the channel shows a decimal point.

- Filtering time: the setting of filtering time helps to improve the smoothness of the signal. The longer the filter time is, the smoother the signal is, but the slower the response is.
- Range: user defined range, upper limit and lower limit, can be configured freely. Press [confirm key] to enter the 'Auxiliary Interface' for quick parameter changes.
- Signal removal : When the measurement signal is small , the measurement error is relatively large , especially below 1 % , the accuracy will be greatly reduced , and the project will generally be zeroing , i.e . cutting off the small flow . When setting a certain percentage , the signal less than the range percentage is forced to be the lower limit of the range .
- Linear adjustment: allows the user to adjust the deviation value of the display value, display data = measurement data*K+B, generally, the adjustment value should be set to 0.
- Cold end compensation: when the cursor is in the cold end compensation setting box, press [confirm key] to switch 'given' or 'external' mode, when in a given mode, The cold end compensation value can be set freely, and the cold end compensation value system can be captured automatically in 'external' mode, the system factory default is 'external' mode.
- ◆ Flow configuration: according to [F1] can enter the secondary flow accumulation parameter setting screen (minimum cumulative value 0, less than 0 cumulative value does not accumulate), the picture details as shown below.
- ① Alarm configuration: according to [F2] can enter the secondary alarm configuration interface, alarm configuration contains alarm threshold, alarm contact, alarm return difference and other parameters, the parameters are described as follows:
 - A. Alarm threshold: the threshold produced by the alarm, which must be within the range of the channel range. This instrument is divided into four categories: upper limit (HH), upper limit (HI), lower limit (Lo) and lower limit

(LL).

B. Alarm contact: relay number, such as contact 01 for relay 01, that is, R1 (display in instrument screen) or K1 (display in instrument wiring mode).

C. Alarm return error: when the signal oscillates near the alarm threshold, the relay acts frequently, which sets a difference (lag) for the occurrence and release of the alarm.

⑫ Copy and paste: copy [F 3] current channel parameter, switch channel serial number paste [F 4] to another channel.

⑬ Operation:

press [F1] to quickly enter the flow accumulation configuration screen;

Press [F2] to quickly enter the alarm configuration screen;

Press [F3] to quickly copy the currently selected channel parameters;

Press [F4] to quickly paste the copied channel parameters to the currently selected channel;

Press [F5] to exit the system configuration screen quickly;

Press [to the left] or [to the right] to move the cursor;

Press [up key] or [down key] to select or adjust the value;

Press [confirm key] to perform cursor location function or edit cursor location data.

Parameter	Value
Flow Mode	Linear
Flow Unit	m ³ /h
Min Range	0
Flow Cut	0.0 %
Medium	Disable
TrmPerature	Set 20.0 °C
Stanrd Temp	20.00 °C
Zn	1.000
Flow Factor	1.000
Max Range	9999
Stanrd Dens	0.798
Pressure	Set 0.600MPa
Stanrd Pres	0.000 MPa
Zf	0.960

YR71V2.3.9XCA

④ Flow model: different Flowmeter can choose different calculation model, this instrument provides 4 kinds of calculation model, differential pressure model is suitable for differential pressure Flowmeter such as standard orifice plate, standard nozzle, etc. Frequency vortex model is suitable for pulse frequency Flowmeter such as vortex street, turbine Flowmeter, linear model is suitable for current output vortex street Flowmeter, electromagnetic Flowmeter, etc. Mass flow calculation formula is detailed in appendix II.

⑤ Square type: differential pressure model can be selected: this machine to open or change the square.

● Input mode: frequency model optional: count frequency value or count pulse number.

○ Flow unit: m^3/h , m^3/min , m^3/s , L/h, L/min, L/s, t/h, t/min, t/s, kg/h, kg/min, kg/s, $\text{k m}^3/\text{h}$, $\text{N m}^3/\text{h}$, $\text{KN m}^3/\text{h}$.

■ Instrument coefficient: the instrument coefficient K is obtained according to a set of signals output by the transmitter and the corresponding flow rate, and then calculated back with the flow model, see appendix II for details.

⑥ Cumulative coefficient: the meter accumulates per second (current value* cumulative coefficient /3600);

The cumulative coefficient is 1 and accumulates at 1/3600 of the current value;

When the cumulative coefficient is 60, it accumulates at 1/60 of the current value per second;

When the cumulative coefficient is 3600, it accumulates at the current value per second.

□ Range upper and lower limits: user defined flow range, freely configurable.

□ Medium compensation: medium compensation includes: no compensation, general gas, superheated steam, saturated steam (temperature), saturated steam (pressure), natural gas, hot water.

□ Temperature channel: external complement time choice source channel, the timing set a given compensation value.

- ◆ Pressure channel: external complement time choice source channel, the timing set a given compensation value.
- ⑬ Standard density: the density of fluid in a standard state (e.g.: 20.00 °C , 0.000Mpa (gauge pressure) in Kg/m³.
- ⑭ Standard temperature: the temperature corresponding to the volume flow after compensation. When the calculation result is volume flow rate, the rated temperature should be set, the parameters of which are determined by the user, and the default temperature of the instrument is 20.00 °C . The result of mass flow calculation is independent of the standard temperature.
- ⑮ Standard pressure: the pressure corresponding to the volume flow after compensation. When the calculation result is volume flow, the rated pressure should be set, its parameters are determined by the user, and the instrument default is 0.000Mpa. The result of mass flow calculation is independent of the pressure of the standard condition.
- ⑯ The compressibility coefficients Zn and Zf : Zn are the compressibility of gases in the standard state and the compressibility coefficient Zf is the compressibility of the gas in the flow state.
- ⑰ Open/close:press [F3] to open / close the current channel traffic accumulation function, display the current channel flow accumulation function when open, edit the adjustment change parameters, show the closed channel flow accumulation function, Tuning change parameters cannot be edited when the state is off.
- ⑱ Clear accumulation: press [F4] to clear all accumulated data prior to the current channel, including the cumulative values in the total profile / flow screen, shift accumulation, daily accumulation, and monthly cumulative report in the query configuration. This instrument supports up to 16 channels of flow accumulation.
- ⑲ Operation: press [to the left] or [to the right] to move the cursor;
Press [up key] or [down key] to adjust data or switch selections;
Press confirm key to perform cursor location function or edit cursor location data;

Press menu key to switch the number of decimal places (cursor must be at the upper and lower limits of the range);

Press [F3] to open / close the channel flow function;

Clean up the accumulated data in accordance with [F4] ;

Press [F 5] to quickly exit the subconfiguration.

5.5 output configuration

Move the cursor to the output entry in the configuration screen, press confirm key to enter the output configuration, the

Parameter	Value
Chnl Unit	05
TarGet Unit	%
Source	CH01
Min Range	0.0
OutPut Mode	4-20mA
OutPut Pin	AO01
Relational	Direct
Max Range	100.0

Exit YR71V2.3.9XCA

- ① Channel serial number: the serial number of the output channel. The number of channels that can be selected is limited by hardware.
- ② Output type: the output signal type selection of the transmission output channel.
- ③ Engineering unit: transmission output engineering unit, independent of measurement signal calculation.
- ④ Output terminal: the position of the output signal on the instrument terminal (that is, the terminal position).

- ⑤ Signal source: the source sampling channel that specifies the output value of the current transmit output channel.
- ⑥ Positive and negative effects: under the positive action, the upper limit of the transmission range corresponds to the upper limit of the output current, the lower limit of the transmission range corresponds to the lower limit of the output current when the default range of transmission is positive, and the upper limit of the range of transmission corresponds to the lower limit of the output current under the counter action. The lower limit of the range corresponds to the upper limit of the output current.
- ⑦ The upper and lower limits of the source range: the upper and lower limits of the transmission and output range of the signal source channel [sampling channel] defined by the user.
- ⑧ Operation: press [to the left] or [to the right] to move the cursor;
Press [up key] or [down key] to adjust data or switch selections;
Press confirm key to perform cursor location function or edit cursor location data;
Exit the configuration quickly by [F5].

5.6 Communications configuration

In the configuration screen, move the cursor to the communication entrance and press the confirmation button to enter the communication configuration.

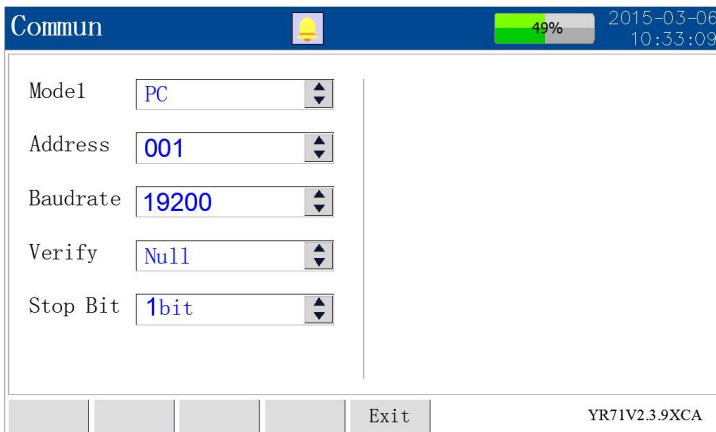

- ① Online mode: including PC and printer two ways to enter the print configuration must first set the online mode as a printer to be effective.
- ② Online address: the communication address is used to distinguish when the instrument is made up of the network. It is the identity of the instrument in the network. The host computer software is used to access the instrument. The local address of the same communication network can be set between 001 and 255, and it can not be repeated.
- ③ Baud rate: when the communication mode is 'printer' mode, baud rate can not be changed.
- ④ Verification mode: no check / odd check / even check, default odd check.
- ⑤ Stop bit: 2 bit / 1 bit, default 2 bit.
- ⑥ Operation: press [F5] to exit the communication configuration quickly;
 Press [to the left] or [to the right] to move the cursor;
 Press [up key] or [down key] to adjust the data or toggle the selection.
 Press confirm to perform cursor location function or edit cursor location data.

5.7 print configuration

Move cursor to print entry in [configuration] screen, press confirm key to enter print configuration, picture description as shown in figure:

Print		2015-03-06 10:33:59	
Print Chnl	01		
Type	Data	Interval	1 S
Begin Data	2015/03/06	Begin Time	10:33:50
End Data	2015/03/06	End Time	10:33:58
Schedule	50%		
<input type="button" value="Stop"/> <input type="button" value="Print"/> <input type="button" value="Exit"/>			YR71V2.3.9XCA

- ① Print channel: user needs to print data / curve passageway.
- ② Print type: the type of content users need to print, data and curves.
- ③ Print interval: time interval when printing data / curve.
- ④ Print range: start and end date of print data / curve, starting and ending date must be earlier than end time date, otherwise data / curve printing cannot be carried out.
- ⑤ Printing progress: the progress of the current printing process is displayed in real time, the filling area is the current printed part, and the middle value of the progress bar is the percentage of the print progress.
- ⑥ Operation: press [F3] to stop printing;
 Start data / curve printing according to [F4];
 Press [F 5] to exit the print configuration quickly.
 Press [to the left] or [to the right] to move the cursor;
 Press [up key] or [down key] to adjust data or switch selections;
 Press confirm to jump quickly (cursor at the beginning and end date).

5.8 backup configuration

Move cursor to backup entry in [configuration] screen, press [confirm key] to enter 'backup configuration', picture description as shown in figure:

USB Disk		2015-03-06 10:36:24	
Backup Chnl	01-06	State	off line
Begin Date	2015/03/06	Begin Time	10:30:50
End Date	2015/03/06	End Time	10:36:24
File Name	0306103.BIN		
Schedule	50%		
Reset		Backup	
Exit		YR71V2.3.9XCA	

- ① Backup channel: the channel number that the user needs to back up the historical data. If 01-01 means that only 1 channel is backed up, 01-06 means that 1-6 channels need to be backed up.
- ② Device status: display U-disk status, online, offline and error status.
- 3 ③ Backup range: date of start and end date of backup data, date of beginning and ending time must be earlier than date of end time, otherwise data backup cannot be made.
- ④ File name: backup file name, can not be changed.
- ⑤ Backup progress: the progress of the current backup process is displayed in real time, the filling area is the current backup part, and the intermediate value of the progress bar is the percentage of the backup progress.
- ⑥ Operation: back up according to [F3] reset;
Press [F4] to start data backup;
Press [F5] to exit the backup configuration quickly.
Press [to the left] or [to the right] to move the cursor;
Press [up key] or [down key] to adjust data or switch selections;
Press confirm to jump quickly (cursor at the beginning and end date).

5.9 display configuration

Move the cursor to the display entry in the configuration screen, press confirm key to enter the display configuration, the picture description is as shown in the figure:

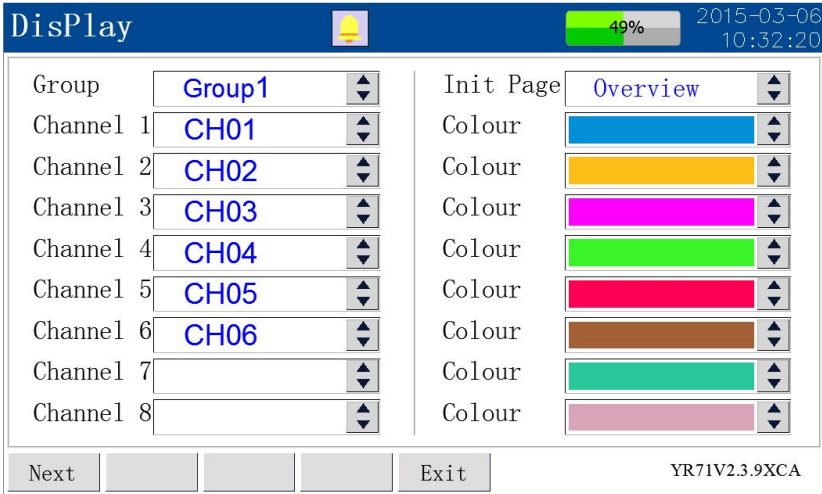

- ① Display combination: select display combination sequence number.
- ② Start screen: select the starting screen to be displayed after the instrument is started.
- ③ Channel association: association with any channel combination or closed channel.
- ④ Curve color: select the display color of each curve.
- ⑤ Operation: press [F5] to exit the display configuration quickly;
Press [to the left] or [to the right] to move the cursor;
Press up or down to switch the selection.

Attention

When the starting picture is selected as a packet picture, the packet screen is a display combination 1 picture under the overall appearance grouping screen.

When all channels under a group display combination are closed, the group display combination is not open.

5.10 Control configuration

Move cursor to control entry in [configuration] screen, press [confirm key]to enter control configuration, picture description as shown in figure:

Loop Number	PID01	Loop State	Close
SV	Set 0.0	Dead Zone	0.0 %
PV	CH01	Ctrl Mode	Manual
MV	0.0 100.0	I	9999 S
P	100.0%	Separate	100.0 %
D	0.0 S		
Inverse	Inverse		

Exit

YR71V2.3.9XCA

- ① Loop serial number: control circuit channel serial number, limited by configuration, up to 4 channels.
- ② Loop state: select channel working state.
- ③ Set value SV: select the source and value of the set value.
- ④ Sample value PVA: select the source of the signal from which the measured values are sampled.
- ⑤ Output value MV: set the upper and lower limits of the loop output.
MV default value: set the MV initial value when cold start.
- ⑥ Set dead zone: set dead zone value (the controlled variable is allowed to change within a specified range), the dead zone is too large, the system control is delayed, the dead zone is too small, the execution mechanism will act frequently.
- ⑦ Control mode: set the manual automatic control mode after cold start or start

control configuration.

- ⑧ Proportional coefficient: set P value of proportional band coefficient.
- ⑨ Integral time: set the integral time I value.
- ⑩ Differential time: set the differential time D value.
- ⑪ Integral separation: set the integral separation value, when the system has big deviation, cancel the integral action, the system deviation is small (the adjusted quantity is close to the given value), the integral takes effect.
- ⑫ Positive and negative action: select control loop action mode.
- ⑬ Operation: copy parameters according to [F3];
Pasting parameters according to [F4];
Press [F5] quick exit control configuration;
Press [to the left] or [to the right] to move the cursor;
Press [up key] or [down key] to adjust data or switch selections;
Press [confirm key] to perform cursor location function or edit cursor location data.

5.11 report queries

In [configuration] screen move cursor to [query] entry, press [confirm key] to enter [report query], picture description as shown in the figure:

Month Logs				2011 / 12 / 12 11:06:00	
		Mon	Cum		
2010-12	200.0				
2011-01	180.0				
2011-02	180.1				
2011-03	180.0				
2011-04	179.9				
2011-05	180.0				
2011-06	180.0				
2011-07	180.2				
2011-08	180.0				
2011-09	180.0				
2011-10	180.1				
2011-11	180.0				
2011-12	68.7				
11Year Cum 2049.0		mL		Total Cum 3897.5 mL	
Days	Time	Demand	ExPort	Exit	

The accumulative monthly report shows the accumulative details of the monthly flow rate of the last month of the year and the year in which the instrument is located, the cumulative value of the annual cumulative value and the current cumulative value of the instrument; the cumulative daily report shows the cumulative details of the daily flow rate of the last day of the previous month and the current month of the year Monthly cumulative value and annual cumulative value of the year in which the cumulative report shows the cumulative details of each shift per day on the last day of the month and the current month, the monthly cumulative total value and the annual cumulative value of the year in which the cumulative report is not updated in real time. Press left or right to refresh the latest data.

Operations: press [to left] or [right] to move the cursor; press [up] or [down] to switch options; press confirm to perform cursor function or edit cursor

location data; press [F5] to exit the report query, [F1]-[F4] see the functional keys.

Attention

After reset or switch class report in system configuration, each channel must be cleared and then used.

Monthly reports show a maximum of 13 months of cumulative records, daily newspapers and shift newspapers show a maximum of 32 days of cumulative records, and the system automatically removes last month's recorded data from the previous year.

5.12 functional information

In the configuration screen, move the cursor to the function entry, press [confirm key] to enter the function information, the picture description is as shown in the figure:

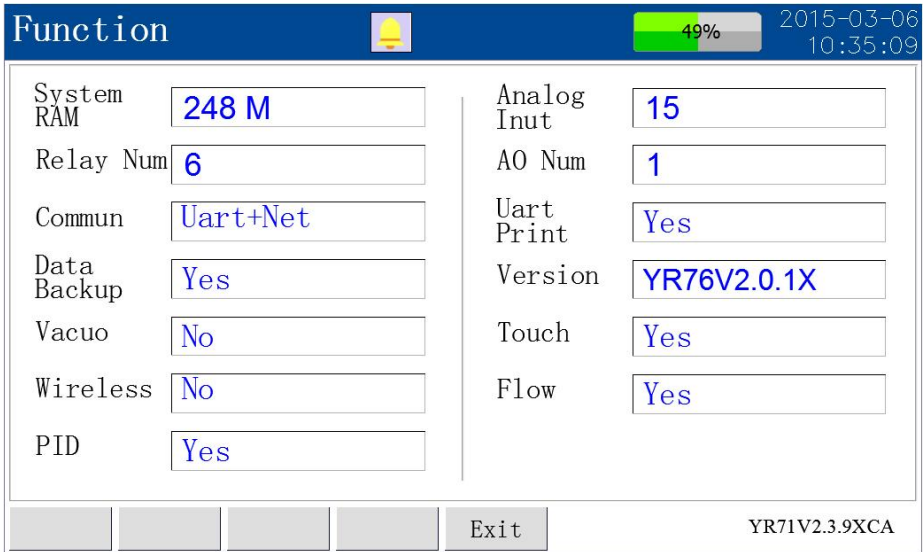

- ① System memory: displays the total memory capacity of the current system configuration.
- ② Analog input: shows the total number of analog inputs for the current system

configuration.

- ③ The number of relays: the total number of relays showing the current system configuration.
- ④ Transmission output: shows the total number of analog outputs for the current system configuration.
- ⑤ Traffic accumulation: shows whether the current system is configured with a traffic accumulation function.
- ⑥ Pid control: shows whether the current system is configured with pid control functions.

- ⑦ Serial communication: shows whether the current system is configured with serial communication module.
- ⑧ Serial port printing: shows whether the current system is configured with serial port printing function.
- ⑨ Data backup: shows whether the current system has data backup function.
- ⑩ Software Version : Displays the version number of the software program for the current system .
- ⑪ Operations: press [F5] to quickly exit function information screen.

5.13 Note and Auxiliary Interface

The system does not open the function, the operation authority is insufficient, clears the power off or the alarm list, recovers the factory to set and so on the operation will pop up the prompt dialog box, the prompt dialog box is shown in the following figure:

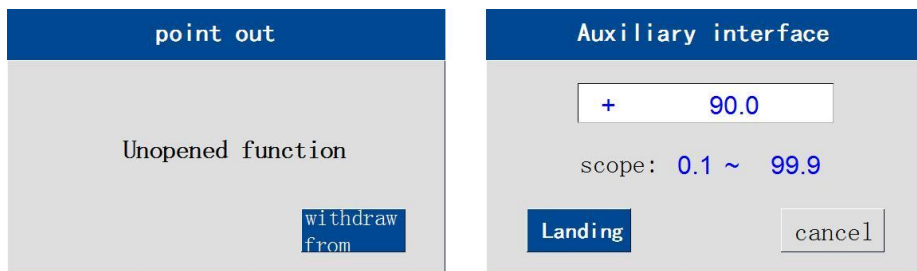

Some parameters can be quickly edited into the auxiliary interface, which is shown above. The auxiliary interface is mainly used for setting the upper and lower limit of alarm, setting up the upper and lower limit of measuring range, etc. Enter the secondary interface (press [confirmation key] to enter the auxiliary interface when you are in the corresponding parameter setting box) and quickly adjust the multi-digit values. Once the values set are beyond the range of settings, the system will prompt to exceed the range of the parameters that can be set, Keystroke operation reference 'keyboard features'.

Chapter VI Fault Analysis and troubleshooting

The paperless recorder adopts advanced production technology and carries out strict test before leaving the factory, which greatly improves the reliability of the instrument. Common failures are generally caused by improper operation or parameter setting. If you find a failure that can not be handled, please record the failure and contact us in time. The following are some troubleshooting and handling measures for this instrument in its daily application:

Fault phenomenon	analysis of causes	Treatment measures
The instrument does not work when it is electrified	1 » Poor contact with power cord 2 » Power switch is not closed	Check power supply
The signal display does not match the actual situation.	2 » Signal setting error in configuration 2 » wiring error	1» Inspection configuration 2» Check signal line
Alarm output abnormal	1» Alarm limit setting error 2» Alarm points shared by other channels	1» Reset the limit 2» Cancel other alarm points
Problems in distribution output	1» Transmitter and instrument wiring error 2» Power distribution with multiple transducers exceeding the standard distribution of this instrument	1» Correct wiring 2» Use external voltage stabilizer to supply power or return to plant to customize maximum load 3» Use independent power supply or return to factory

	<p>3》 Interference between digital and analog signals during distribution</p>	
<p>USB Transfer failure</p>	<p>1》 Incorrect start and end time settings 2》 U disk format is incorrect 3》 U disk incompatibility 4》 Insufficient spare space on U disk 5》 Misoperation during backup</p>	<p>1》 Setting time correctly 2》 Format U disk to FET32 3》 Use a genuine compatible U disk 4》 Use larger capacity U disk or clear redundant files in U disk. 5》 proper operation</p>
<p>No data or abnormal display in USB transfer file</p>	<p>1》 No data for the time period selected by the user 2》 User changed system time 3》 User changed signal type 4》 The user sets the record interval too big, but the backup time is very short 5》 U disk incompatibility 6》 The time period of the data is too long, which exceeds the maximum read time</p>	<p>1》 Select the time to have a data segment 2》 Erasing the primary data area 3》 No impact on data recording 4》 Record interval is set to be small or backup time is longer 5》 Use a genuine compatible U disk 6》 The time period for backing up the data is smaller, piecewise and batch backup</p>

	domain of the upper computer software.	
No communication.	<p>1》 The communication cable is not connected</p> <p>2》 Communication parameter setting error</p> <p>3》 Serial communication setup error</p>	<p>1》 Properly connected communication line</p> <p>2》 The setting of the communication parameters of the recorder and PC is consistent.</p> <p>3》 Set up the correct com port (make sure it is not occupied by another program)</p>

Chapter VII Service Guide

Respected user: Hello! Thank you for choosing the instrument of our department. Our company will thank you for your trust in our company with excellent service. For the first time, check whether the actual configuration of the product is consistent with the instrument configuration sheet, random data, accessories and other packing items are complete. If you have any objection, please contact us first.

matters need attention

Read random materials: please read random materials and warranty principles carefully, and complete storage.

After purchasing machines, properly keep the invoices.

Warranty principle

maintenance cycle

Five working days from the date of receipt of the product.

maintenance and repair cost

This series of ultra-thin wide-screen color paperless recorder free warranty for one year (product quality issues).

The warranty period shall be calculated from the date of purchase and shall be supported by the customer's purchase invoice (indicating the product model, host serial number) or photocopy. If the invoice is not available, it will be calculated from the date of our production.

Warranty period, due to improper use of the customer damaged products, or the customer has opened the product qualified seal, a certain fee. After product repair, free warranty for six months.

Customer advice

Please be sure to send back the product with product breakdown instructions to help the engineer fix it as soon as possible.

Please fill in the telephone / fax number, correspondence address and contact person accurately for the return of maintenance products.

If you want the engineer to go to the site to carry out repairs, you will have to bear the expenses incurred therefrom.

We usually send it back by express (not with insurance). If you need to ship it by other party, please indicate it in the form and pay the related expenses.

Appendix I digit configuration

The bit number configuration screen is shown in Appendix 1.1 of the figure, as follows:



✿Input method:

Pinyin: used for input of Chinese characters;

English / A: used for uppercase English character input;

English / a: used for lowercase English character input;

Number: used for numeric character input;

Special symbol: used for special symbol input;

Operations: press [up key] or [down key] to switch input method, press [right button] to move to channel bit number function box.

✿Channel bit number:

This area displays the location number, which can display up to 5 Chinese characters or 10 ordinary characters or combinations of Chinese characters and common characters (1 Chinese characters =2 ordinary characters).

◎ Operations: press [F1] function key to save bit number modification, [F2] function key cancel bit number change, [F5] function key drop box, press [right button] or [down key] to move to Pinyin / English / number / symbol selection function box, Press left or up to move to the input function box.

✱Pinyin / English / number / symbol selection:

① **Pinyin selection:** when the cursor is in the phonetic selection function box, when the cursor is in the phonetic selection function box, a variety of phonetic combinations may appear after entering Pinyin letters by pressing the [F1], [F2], [F3] or [F4] function keys, A screen displays up to 4 phonetic combinations. Operations: press [left button] or [right button] to move cursor or pinyin select page turning, press down key to move to Chinese character selection function box, press up key to move to channel bit number function box.

② **English / number / symbol selection:** press [left key] or [right button] to move cursor, press confirm key to select character, press [up key] to move in function box. Press down to move to the input method function box.

✱Chinese character selection:

Select the desired Chinese characters. Action: press [left button] or [right button] to move cursor around, press [up button] to move cursor or move to Pinyin selection function box, press [down key] to move cursor down or move to input method function box.

For example: the first channel requires a bit number of "1# tower temperature", the bit number modification steps are as follows:

- ① enter the bit number to modify the screen, the default bit number for "01 channel";
- ② press [up key] or [down key] to switch input method to [number], then press [right-click] to channel bit number function box, press [F5] function key to drop all default "01 channel", Then press right-click to the number selection function box, at this time the cursor stays on the number [1] press the confirmation key, select the back channel number function box horizontal bar automatically move back one, press [down key] to return to

the input method function box.

- ③ Press ② -step operation to complete "#" character input and return the cursor to the input method function box.
- ④ press [up key] or [down key] to switch the input method to [Pinyin], press [right-click] to move the cursor to the phonetic selection function box, and then press the [F4], [F1] function keys where the letters "t", "a" are located, Press [right-click] to move the cursor to "ta", the picture is shown in [Appendix 1.2](#), if the input error, press the [F5] function key to delete the newly entered letter.
- ⑤ After selecting Pinyin, press [down key] to move to the Chinese character selection function box, and then press [right-click] to move the cursor to the "tower". The picture is shown in [Appendix 1.3](#):

Select a good Chinese character and press confirm key to confirm the input of Chinese character. At this time, the horizontal bar at the function box of the channel bit number automatically moves back one, then repeat the operation 4 / 5 steps in a similar manner. After all the bit numbers are set up, as shown in [Appendix 1.4](#) of the figure, Press [F1] to save the set bit number, and the system automatically returns to the input configuration screen.

Note: when you press [F2] to cancel the function key, the system does not save the set bit number. Then return to the input configuration screen.

Appendix II flow calculation formula and instrument coefficient

Appendix 2.1 Mass flow calculation Formula

① Difference pressure flow meter: $Q = K * \sqrt{\Delta P * \rho}$...Type appendix 2.1-1

K : Instrument coefficient ΔP : Input differential pressure value

ρ : Dielectric density

② Vortex Flowmeter (K coefficient unit is secondary / m³):

$$Q = 3600 * I_f * \rho / K \dots\dots\dots \text{Type appendix 2.1-2}$$

K : Instrument coefficient I_f : Vortex frequency

ρ : Dielectric density

③ Linear Flowmeter: $Q = K * \rho * \Delta P$ Type appendix 2.1-3

K : Instrument coefficient ΔP : Linear signal (volume value)

ρ : Dielectric density

Appendix 2.2 instrument coefficient

① When the model is selected as [differential pressure], the coefficient of flow meter is:

$$K = \frac{Q}{\sqrt{\Delta P * \rho}} \dots\dots\dots \text{Type appendix 2.2-1}$$

- ② When the model is selected [frequency vortex street], the unit of instrument coefficient is by default less than m, and the unit and coefficient value of instrument coefficient are set to the unit and coefficient value of Flowmeter (if the Flowmeter unit is less than L, the instrument coefficient = Flowmeter coefficient is 1000).
- ③ In the product channel, the volume upper limit is set to the flow value corresponding to the upper limit of linear signal, and the lower limit is set to 0. Both the flow and volume units participate in the operation. When the medium is compensated, the density takes part in the calculation, and the flow coefficient is calculated according to the calculation formula of linear Flowmeter.

Appendix III types of compensation and gas density in common use

Appendix 3.1 types of dielectric compensation

① No compensation

When the system does not have temperature and pressure compensation, the density is fixed at $1.000\text{kg} / \text{m}^3$ by default.

② General gas

The purpose of general gas compensation is to convert the working condition volume into the volume flow rate under the standard condition.

The equation of state of general gas accords with the equation of state of ideal gas, and the relation between the density of working condition ρ_f and

the density of standard condition ρ_n accords with the following formula:

$$\rho_f = \rho_n * \frac{(273.15 + T_n) (0.10136 + P_f)}{(273.15 + T_f) (0.10136 + P_n)} \quad \dots\dots\text{Type appendi 3.1-1}$$

Among, Standard temperature $T_n = 20.00^\circ\text{C}$, Standard pressure (gauge pressure)

$P_n = 0.000\text{Mpa}$, T_f Operating temperature, P_f Working pressure (gauge pressure).

③ saturated steam

The purpose of compensation for saturated steam is to obtain mass flow.

According to the saturated steam pressure (or temperature) density meter to find the working condition density, realize the pressure (or Temperature) compensation. At this point, the density ρ in the orifice plate of the flow model is input according to the actual input pressure (or temperature)

density obtained by checking saturated steam pressure (or temperature) density table in order to do so.

④ superheated steam

The purpose of compensation for superheated steam is to obtain mass flow.

$$\rho_f = \rho_n * \frac{(273.15 + T_n)(0.10136 + P_f)}{(273.15 + T_f)(0.10136 + P_n)} * \frac{Z_n}{Z_f}$$

The temperature and pressure compensation is realized by checking the working condition density according to the superheated steam density meter.

Current flow the density ρ in the hole plate of the model is the working condition density ρ_f obtained by checking the superheated steam density meter according to the actual input pressure and temperature.

⑤ natural gas

The purpose of natural gas compensation is to convert the working condition volume into the volume flow rate under the standard condition.

The equation of state of natural gas accords with the equation of state of ideal gas, and the relation between the working condition density and the standard density conforms to the following formula:

.....Type appendi 3.1-2

Standard temperature $T_n = 20.00 \text{ }^\circ\text{C}$, Standard pressure (gauge pressure) $P_n = 0.000\text{Mpa}$, T_f Operating temperature, P_f Working pressure (gauge pressure), Z_n For the compressibility of natural gas in the standard state, Z_f The compressibility coefficient of natural gas in flowing state.

$$\rho_f = \rho_n * \frac{(273.15 + T_n)(0.10136 + P_f)}{(273.15 + T_f)(0.10136 + P_n)} * \frac{Z_n}{Z_f}$$

Appendix 3.2 common gas density

The standard densities of commonly used gases at 1 standard atmospheric pressure and 20 °C are as follows(For kg /m³):

Air (dry): 1.2041

Nitrogen: 1.1646

Oxygen: 1.3302

Helium: 0.1664

Hydrogen: 0.0838

Krypton: 3.4835

Methane: 0.6669

Ethane: 1.2500

Propane: 1.8332

Ethylene: 0.9686

Propylene: 1.7495

carbon monoxide: 1.165

Carbon dioxide: 1.829

Hydrogen Sulfide: 1.4169

Sulfur dioxide: 2.726

Appendix IV examples of traffic usage

Example 1: measurement of mass flow of superheated steam with standard orifice plate

Known: differential pressure sensor: Two-wire 4-20mA differential pressure transmitter, the instrument needs to be square, measuring range 0.000-4.000KPa, corresponding volume flow range 0~500m³/h.

Pressure sensor: two-wire 4-20mA transmitter, measuring range 0.00-0.50 MPa.

Temperature sensor: Pt100

Working condition: 230 °C, 0.3MPa (gauge pressure), corresponding to maximum flow rate 500m³/h

Settings: input configuration:

- 1.Signal type selection [4~20mA]
- 2.Engineering Unit selection [KPa]
- 3.The lower limit of the range is 0.000, the upper limit of the range is 4.000
- 4.Other parameters are set according to need [the alarm configuration in the input configuration of open flow operation channel is called flow alarm]

Flow accumulation:

- 1.Model selection [differential pressure]
- 2.Prescription type selection [native prescription]
- 3.The unit of flow: [Kg / h]
- 4.Instrumentation coefficient K: [330.8]
- 5.Upper limit of flow range, set according to actual mass flow range
- 6.The lower limit of the flow range is generally 0
- 7.Medium - compensated selection of superheated steam boiler
- 8.Temperature channel: the temperature channel is divided into a given and an outer complement, and if a given is selected, a given temperature is entered thereafter; if an external complement is selected, the

temperature channel number is then selected,

9. Pressure passage: a pressure channel is divided into two parts: if given, the given pressure is entered at the back of the selection, and if the external patch is selected, the pressure passage number is selected after the selection.

10. Density, temperature, pressure, coefficient of compression, coefficient of compression are ignored

Note: instrument coefficient calculation process:

The results show that the superheated steam has a density of 1.7513 kg / m³ under the condition of 230°C, 0.3 MPa (gauge pressure).

$$K = \frac{Q}{\sqrt{\Delta P \rho}} = \frac{500 * 1.7513}{\sqrt{4 * 1.7513}} = 330.8$$

Fill in the results of the calculation.

Example 2: volume flow of water measured by electromagnetic Flowmeter

Known: electromagnetic sensor: Two-wire 4-20mA transmitter, corresponding flow range 0.00~25.00m³ / h

Setup: enter configuration:

1. Signal type selection [4~20mA]
2. Engineering units select [m³ / h]
3. The lower limit of the range is [0.00], the upper limit of the range is [25.00]
4. Other parameters are set as needed

Flow accumulation:

1. Model selection [linear]
2. Flow unit selection [m³ / h]
3. Instrument coefficient set to [1.000]
4. Upper limit of flow range set to [25.00]
5. The lower limit of flow range is generally taken [0.00]
6. Medium compensation selection [no compensation]
7. Other parameters are set as required

An example of Application of PID Control Circuit in

Appendix 5

As shown in the diagram, a PID single-loop control system with a 2-channel series of instruments is used to realize a simple temperature control. The measuring signal is the temperature in the tank and the output signal acts on the heating wire (assuming that the heating wire can receive continuous signals).

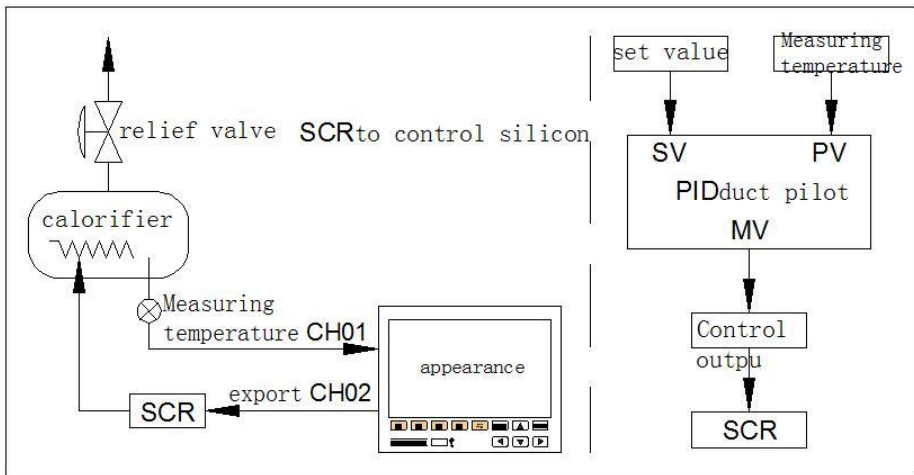

flow path

schematic diagram

Configuration process:

- System configuration: pid tuning selection allows (for adjusting pid screen parameters).
- Input configuration: temperature channel CH01, parameter user defined.
- Output configuration: output channel CH02, signal source set to PID01, other parameters user defined.
- Control configuration: control channel PID01, loop state selection enabled, set value SV selection given in the selection, sampling value PV select CH01, other parameters user-defined.

Adjustment process (in the PID screen):

- ✿ In the pid screen manually adjust the MV, so that PV near the set value.
- ✿ Set the loop state automatically and observe whether the sampling value PV meets the requirements.
- ✿ Adjust PID parameters to make the loop stable.