

## Foreword

Thank you for purchasing the Enhanced Color Paperless Recorder.

The use's manual contains useful information about the functions of the instrument, installation, operation procedures, parameter setting and troubleshooting . To ensure correct use, please read this manual carefully before installation and operation. And keep this manual in a safe place for quick reference in the event a question arises.

## Packing Details

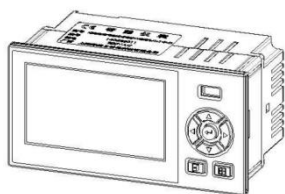

Enhanced Color Paperless Recorder

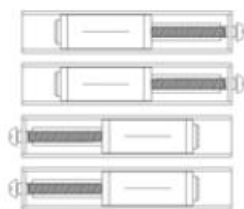

Mounting Bracket



User's Manual



Quality Certification



Data Management Software (CD)

| No. | Name                                    | Unit | QTY | NOTE                                |
|-----|---|------|-----|-------------------------------------|
| 1   | Enhanced Color Paperless Recorder       | pcs  | 1   |                                     |
| 2   | Mounting Bracket<br>(with screws)       | pcs  | 2   | Suit for embedded installation mode |
| 3   | User's Manual                           | book | 1   |                                     |
| 4   | Quality Certification/<br>Warranty Card | pcs  | 1   |                                     |
| 5   | Data Management Software<br>(CD)        | pcs  | 1   |                                     |
| 6   | RS232C/485 Convert Modula               | pcs  |     | optional                            |
| 7   | RS232C Lines                            | pcs  |     | optional                            |
| 8   | U Disk                                  | pcs  |     | optional                            |
| 9   | Micro Printer (accessory)               | pcs  |     | optional                            |

## Attention

- If you find that the instrument is damaged by transportation, please contact the manufacturer.
- This series of instruments is suitable for general industrial occasions. If you have special use requirements, please set up a separate protective device.
- For the safety of you and the instrument, please do not install with electricity. Please use the rated voltage power supply, the correct wiring, properly grounded, after the power supply, please do not touch the back of the instrument wiring terminal, in case of electrical shock.
- The instruments should be installed indoors, and the installation position is to ensure that the ventilation is smooth (in case the temperature inside of the instrument is too high), avoid the wind, rain and direct sunlight, do not install in the following situations:
  - An occasion where temperature and humidity exceed the conditions of use
  - An occasion in which a corrosive, flammable or explosive gas is present.
  - Occasions with large amounts of dust, salt and metal powder.
  - Occasions where water, oil and chemical liquids are easily splattered.
  - An occasion of direct vibration or shock.
  - Electromagnetic source.
- The instrument should take appropriate shielding measures when it is close to power line, strong electric field, strong magnetic field, static electricity, noise or AC contactor, etc.
- In order to avoid measuring error, when the sensor is thermocouple, please use the appropriate compensatory wires. when the sensor is thermal resistance, use three copper conductors of the same size and resistance value less than  $10\ \Omega$ , otherwise the measurement error will be caused.
- In order to extend the service life of the instrument, please carry out regular maintenance and maintenance. Do not repair and disassemble the instrument by yourself. When wiping the instrument, please use a clean soft cloth, do not dip in alcohol, gasoline and other organic solvents cleaning, may cause discoloration or deformation.
- If the meter has influent, smoke, smell, noise and so on, please immediately cut off the power supply, stop using and get in touch with the supplier or our company in time.

# Catalogue

|  |    |
|--|----|
| Chapter 1 Technical Indicators .....                                 | 4  |
| Chapter 2 Installation Wiring .....                                  | 6  |
| 2.1 Instrument Structure .....                                       | 6  |
| 2.2 Instrument Dimensions .....                                      | 6  |
| 2.3 Size Of Opening .....  | 7  |
| 2.4 Instrument Installation .....                                    | 7  |
| 2.5 Instrument Wiring .....  | 8  |
| Chapter 3 Basic Operation and Running Picture .....                  | 11 |
| 3.1 Instrument Keys .....  | 11 |
| 3.2 Usage Patterns .....   | 12 |
| 3.3 Status Markers .....   | 12 |
| 3.4 Overview Appearance .....  | 13 |
| 3.5 Bar Graph Photo .....  | 14 |
| 3.6 Real-time curves .....   | 15 |
| 3.7 Historical Curve .....   | 16 |
| 3.8 Alarm List .....   | 17 |
| 3.9 List of power off .....  | 18 |
| Chapter 4 Parameter Settings and Auxiliary Operation .....           | 19 |
| 4.1 Configuration Login .....  | 19 |
| 4.2 Configuration Picture .....                                      | 20 |
| 4.3 System Configuration .....                                       | 21 |
| 4.4 Input Configuration .....  | 22 |
| 4.5 Output Configuration .....                                       | 24 |
| 4.6 Communications Configuration .....                               | 25 |
| 4.7 Print Configuration .....  | 27 |
| 4.8 Backup Configuration .....                                       | 28 |
| 4.9 Display Configuration .....                                      | 29 |
| 4.10 Report Status .....   | 30 |
| 4.11 Note and Assist Interface .....                                 | 32 |
| Chapter 5 Fault Analysis and Troubleshooting .....                   | 33 |
| Appendix 1 Bit Configuration .....                                   | 35 |
| Appendix 2 Flow Calculation Formula .....                            | 38 |
| Appendix 3 Flow Function .....                                       | 39 |
| Appendix 4 Types of compensation and gas density in common use ..... | 43 |
| Appendix 5 Examples of traffic usage .....                           | 45 |

## Chapter 1 Technical Indicators

- **Display**

Screen: 7-inch true-color TFT LCD

Accuracy: Real time display:  $\pm 0.2\%$  F.S.

Recall Accuracy:  $\pm 0.2\%$  F.S.

(Note: thermocouple should remove cold end error)

- **Processor**

High performance arm Cortex-M3 32 bit RISC core .

- **Input Function**

Input Specification: maximum support 6 analog input

Voltage Input: 0-5V, 1-5V, 0-20mV, 0-100mV

Current Input: 0-10mA, 4-20mA, 0-20mA

Resistor Input: Res (0 ~ 400  $\Omega$ )

Thermal Resistance: PT100, Cu50, G53, Cu100, BA1, BA2

Thermocouple: S、 B、 K、 T、 R、 E、 N、 J

Radiation Pyrometer: F1、 F2

Tungsten Rhenium: WRe3-25 WRe5-26

### Attention

Other input signals (e.g: 0-10v), indexing number (e.g PT1000), or pulse input (PI) should be specified when ordering.

- **Output Function**

Distribution Output: 1 set of transmitters are supported for isolated distribution + 24VDC, each group of distribution  $\leq 60\text{mA}$ , support other specifications of isolated distribution (e.g. 12VDC / 5VDC distribution output).

Transmission Output: support up to 2 channels 4-20mA standard current output, load capacity 500  $\Omega$  (maximum), convenient display instrument or DCS / PLC acquisition, achieve long distance signal transmission.

Relay alarm output: up to 2 relay alarm output, contact capacity 3A@ 250VAC / 3A@ 30VDC, can be configured upper limit, lower limit alarm.

- **Communication Printing**

Communication Interface: providing RS232C and RS485 communication interfaces for users to choose from, supporting Modbus RTU protocol, baud rates- (1200,4800,9600,19200,38400,57600)

Print interface: RS232C direct connection to micro printer, baud rate 1200.

- **Power Supply**

Power supply: 220VAC, 50HZ AC power supply, support 24VDC (18VDC-36VDC)  
DC power supply, support 12VDC (9VDC-18VDC) DC power supply.

**Attention**

● **Error Precision**

Compensation error at cold end of thermocouple:  $\pm 2$  °C

Clock error:  $\pm 2$  seconds / day

● **Working Environment [prohibited from working in flammable, corrosive]**

Working temperature: 0 °C 50 °C (avoid direct sunlight)

Relative humidity: 0 / 85R.H (without condensation)

Altitude: < 2000m (other than special specifications).

● **Instrument Net Weight**

Net weight:  $\leq 1.0$  kg

**Attention**

◎The technical index is the general index of this series instrument, the function configuration please take the material object as the standard.

◎If the technical index is inconsistent with the physical instrument , please take the object in kind .

# Chapter 2 Installation Wiring

## 2.1 Instrument Structure

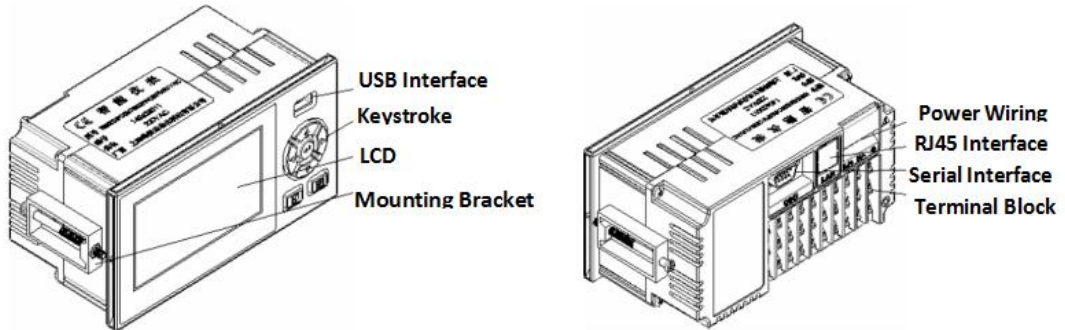

## 2.2 Instrument Dimensions

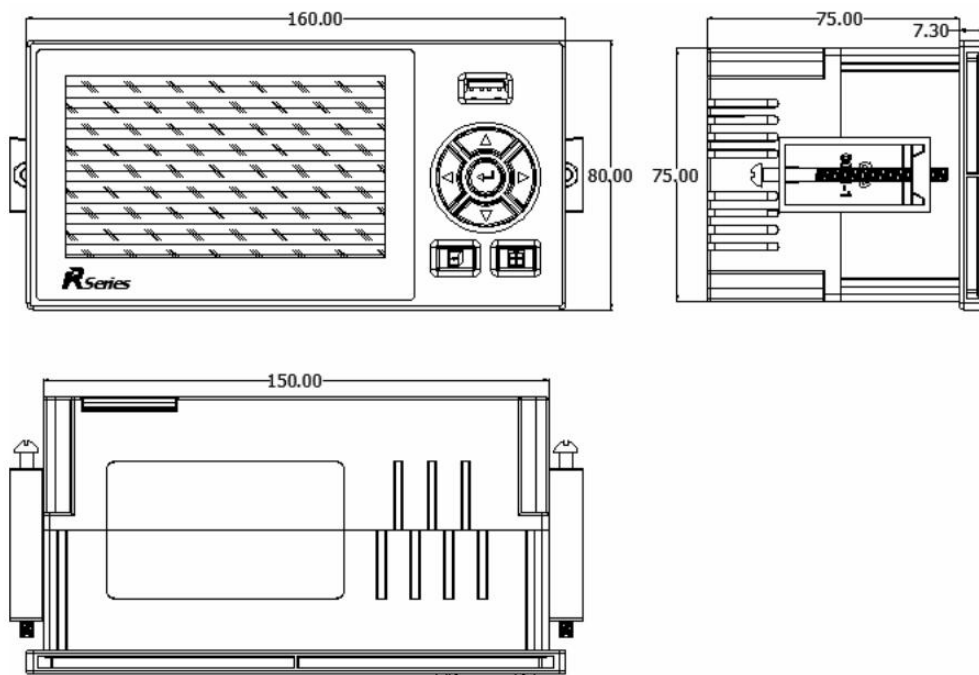

The above graphic unit: mm

## 2.3 Size Of Opening

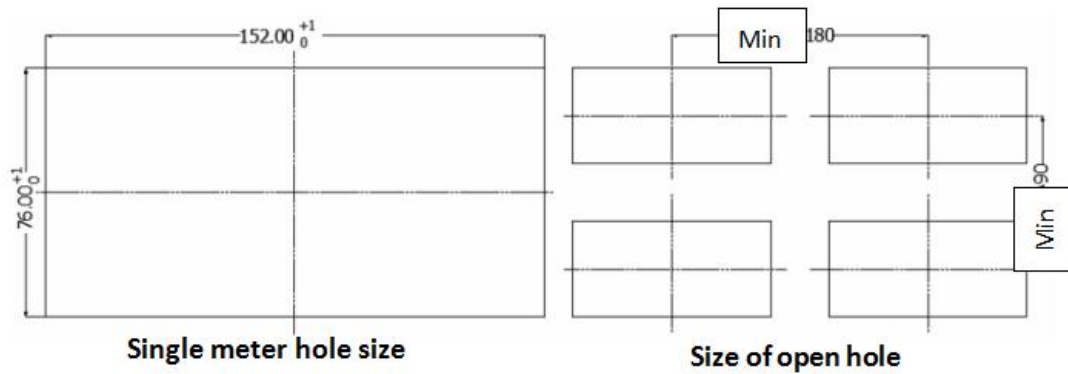

When assembling the meter, refer to the minimum spacing between meters recommended in the above table to ensure the necessary heat dissipation and loading and unloading space.

## 2.4 Instrument Installation

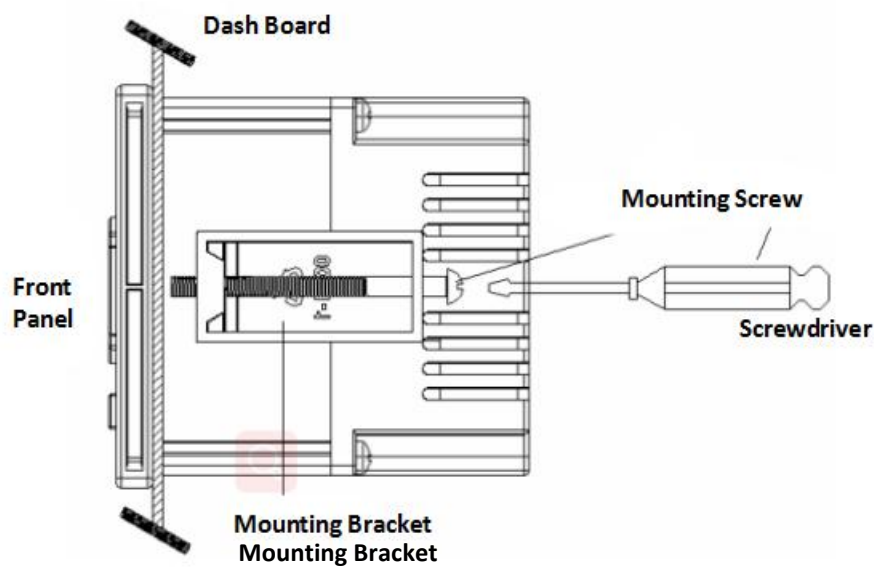

## Installation Method:

- ◎ Step 1: push the meter into the installation hole from the front of the mounting panel (please use the steel plate). The thickness of the mounting panel is (1.5 ~ 6.5) mm.
- ◎ Step 2: install the mounting bracket with the instrument as shown above (two supports on both sides of the instrument and M4 standard screw for the instrument panel mounting bracket).
- ◎ Step 3: after the meter body is installed, the signal line and power line can be connected.

## 2.5 Instrument Wiring

### Wiring Methods

U-type voltage terminal with insulated sleeve (M 3.5 screw for power terminal and M 3 screw for signal terminal) is recommended.



In order to improve the safety of the instrument, please follow the following warning when wiring.



### Attention

- ◎ To prevent electrical shock, make sure the power supply is cut off before connecting.
- ◎ To prevent fire, please use double insulated wires (lines with cross sectional area  $\geq 1\text{mm}^2$ ; Insulated wire 600V; conductors with high voltage resistance and cross section  $\geq 0.5\text{mm}^2$ ).
- ◎ Please set the air switch in the power supply loop to separate the table from the total power supply.
- ◎ Tighten the terminal screw firmly.
- ◎ After the power line is connected, the power supply should be connected to check whether the instrument is normal or not. Please do not connect the signal line until it has been confirmed that the instrument can work normally, and then disconnect the power supply and carry on the connection of the signal line.
- ◎ The measuring circuit and the power circuit need to be laid separately, the object of measurement should not be an interference source, once it is unavoidable, please insulate the measuring object from the measuring circuit, and grounding the measuring object.
- ◎ For electrostatic interference, the use of shielding lines is better.
- ◎ For the interference caused by electromagnetic induction, it is better to equip the measuring circuit with equal distance.
- ◎ If the input wiring is connected in parallel with other instruments, the

measurement value will be affected. Be careful not to switch off the power supply of one of the instruments when you have to run in parallel. This will have a negative impact on other instruments. The thermal resistance cannot be paralleled in principle, and the current signal can not be parallel in principle.

◎When entering thermocouples, please do not use thick lines with good heat dissipation (cross sectional area < 0.5mm<sup>2</sup>), and try not to cause external temperature changes (especially if the switches of nearby exhaust fans will cause larger temperature changes). Platinum resistance input should be less than 10 Ω per lead resistance (lead resistance value is the same).

## Terminal Description

| Terminal name  | Explain   |
|--|---|
| L/+、N/-、  | L is the AC power source phase line end, N is the AC power source zero end,  the wire end is the ground end, + is the DC power source positive end, - is the DC power supply negative end, the DC power supply, please indicate when ordering. |
| A+、B-  | Signal transmitter and receiver of RS485 communication interface  |
| R1~R2  | Relay output port 250VAC /3A@30VDC/3A   |
| E、F  | The positive and negative ends of the transformer output(dc current)  |
| P+、P-  | Feed output positive and negative   |
| A、B、C  | Analog input  |
| COM  | RS232C communication interface / serial interface print interface (where 2 feet are RXD instrument signal receiving terminal and 3 pin is TXD instrument signal transmitter terminal 5 pin is signal ground end)  |
| LAN  | Ethernet RJ45 interface   |

**Note: Touching the terminal while electricity are strictly prohibited**

## Wiring Diagram

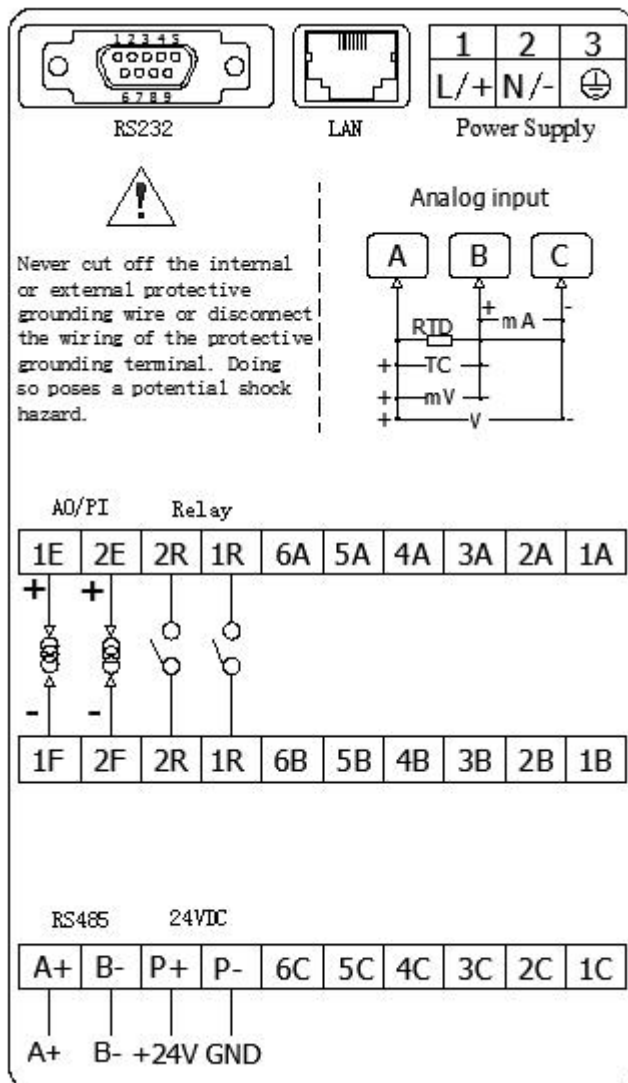

### Attention

- ◎ The power supply voltage at the project site shall be limited to the withstand voltage range of the instrument.
- ◎ This machine often opens the factory by default, the other way to leave the factory please indicate when ordering.
- ◎ Please do not plug and pull the communication cable, if you need to operate, do it after the power supply of the instrument is off.
- ◎ If the wiring diagram is inconsistent with the physical instrument, please take the object in kind.

## Chapter 3 Basic Operation and Running Picture

### 3.1 Instrument Keys

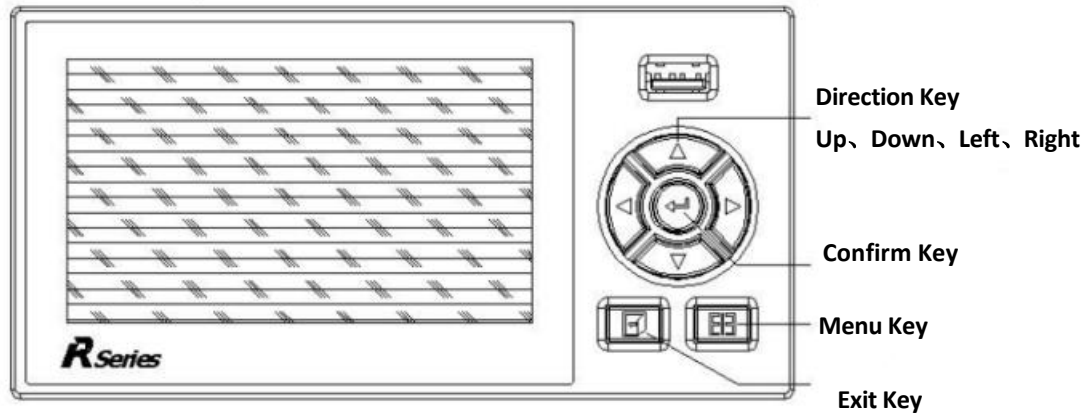

#### Keyboard Function

- ◎ Upward key: move the cursor up, switch to select or increase cursor data values, etc.
- ◎ Down key: move the cursor down, switch to select or reduce cursor values, etc.
- ◎ Left key: Move the cursor to the left or forward, etc.
- ◎ Right key: Move the cursor to the right or back, etc.
- ◎ Confirm key: Perform cursor location function or edit cursor location data, etc.
- ◎ Exit Key: Exit the current screen.
- ◎ Menu key: Switch main display pages, etc.
- ◎ Exit Key and Menu key: Hold down more than 1 second at the same time, enter the configuration Interface.

### 3.2 Usage Patterns

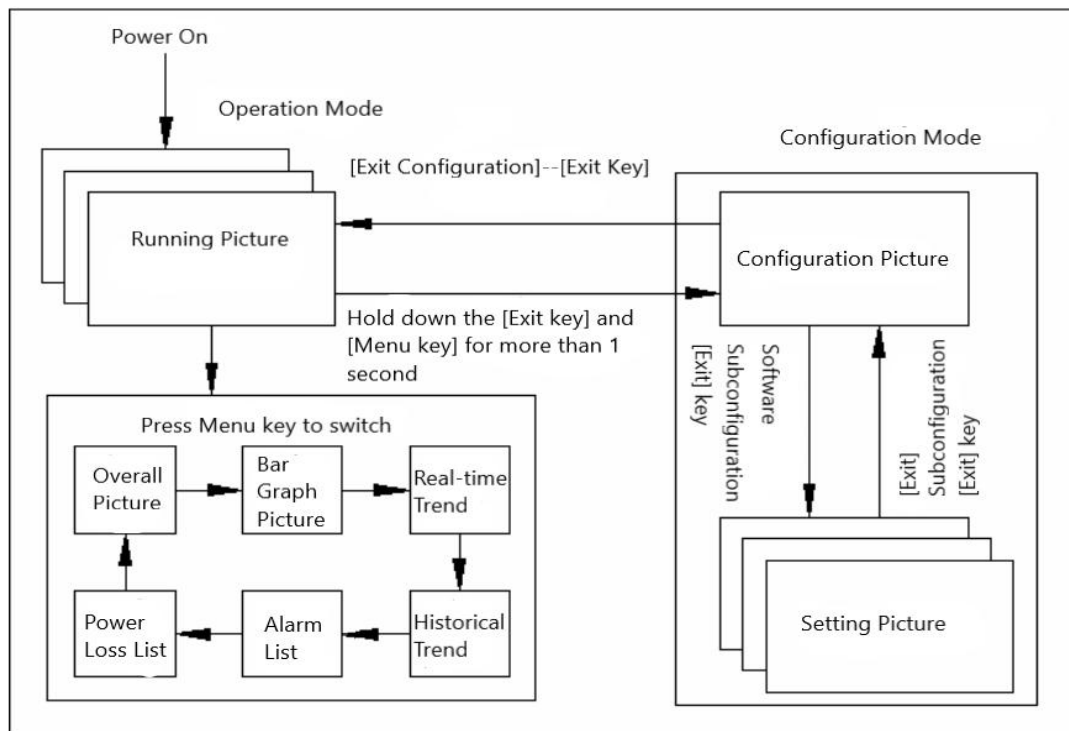

◎To login configuration parameter setting screen, press and hold [exit] + [menu] for one second or more.

◎The running screen can be switched by pressing the menu button.

### 3.3 Status Markers

| Symbol | Name                | Explain   |
|--------|---------------------|---|
|        | USB Equipment Mark  | Detected USB and meter connection   |
|        | Loop Switching Mark | Cycle with the running screen   |
|        | Sound Allowed Mark  | Allows the system buzzer to make sound while operating the button         |
|        | No Sound Mark       | Prohibited the system buzzer from making sound while operating the button |
|        | System Alarm Mark   | System has alarm generated  |

#### Attention

◎If not detected USB and meter connection, will not show USB equipment mark.

◎When you not open the loop switching function, it will not show loop switching mark.

◎When the system has no alarm generated, it will not show system alarm mark.

### 3.4 Overview Appearance

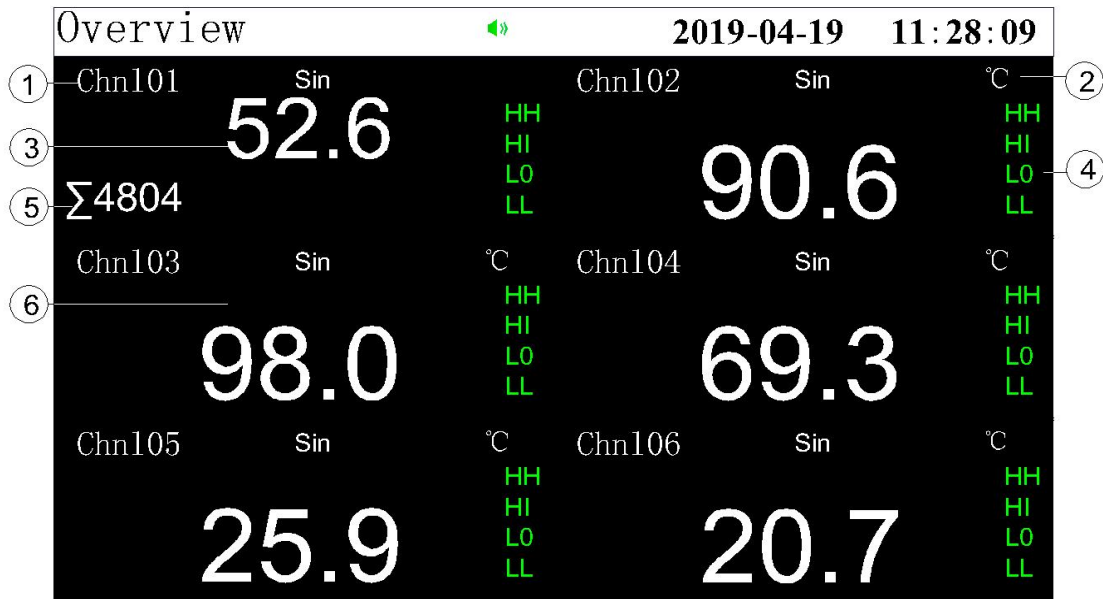

- ① Project bit number: show the corresponding project bit number of channel, can be configured freely.
- ② Unit: the engineering unit that displays the passage is freely configurable.
- ③ Real time data: display the engineering quantity measurement / operation data of the channel. If the current channel is in alarm state, the measurement / operation data will turn red.
- ④ Alarm Status: From top to bottom is the upper limit HH / upper limit HI/ lower limit LO / lower limit LL respectively, red means over-limit alarm.
- ⑤ Signal Types: The current channel primary instrument or detecting components exporting signal types.
- ⑥ Operation: Press [Menu] key to switch bar graph picture.

### 3.5 Bar Graph Photo

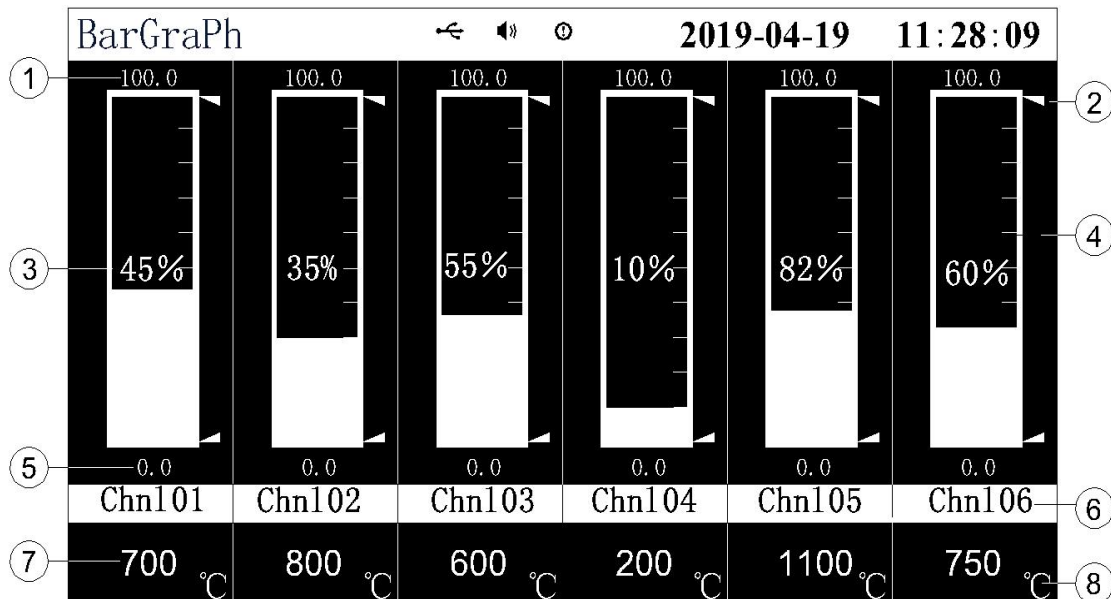

- ① Upper limit of range: The user's defined range, freely configurable.
- ② Alarm Status: From top to bottom is the upper limit HH / upper limit HI / lower limit LO/ lower limit LL respectively, red means over-limit alarm.
- ③ Bar Diagram: The length of bar icon ruler is 10 lattice, the bar graph fill area represents the percentage of the current data in the total program.
- ④ Percentage of data: The percentage of current data in the total process.
- ⑤ Range lower limit: user defined range, freely configurable.
- ⑥ Project bit number: Show the corresponding project bit number of channel, can be configured freely.
- ⑦ Real time data: Display the engineering quantity measurement / operation data of this channel, if the current channel is in alarm state, the measurement / operation data will turn red.
- ⑧ Unit: the engineering unit that displays the passage is freely configurable.
- ⑨ Operations: Press [Menu] key switch to real time curve picture.

### 3.6 Real-time curves

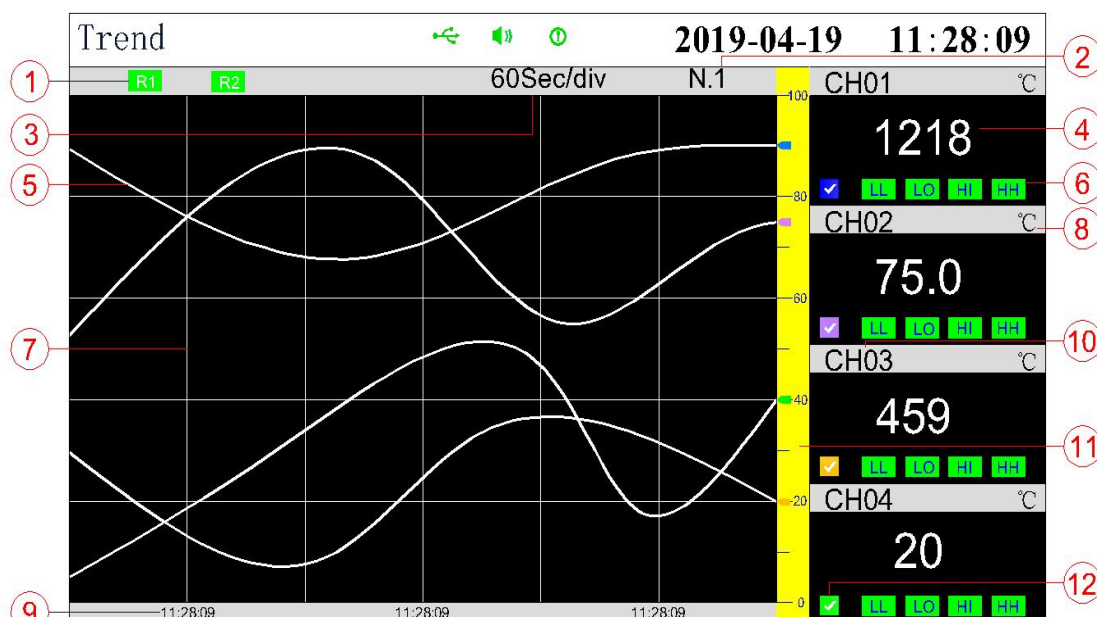

① Relay Status: Displays the current relay output status , the red is in the alarm state , the green represents the normal state , and the black representative does not match the corresponding relay.

② Display combination: Current display combination number, freely configurable. When all combinations are not configured, the instrument will be combined in channel order, 4 channels per group. Display combination can cycle automatic switch, cycle automatic switching function can be freely configured in the [system configuration].

③ Time Scale: The length of time represented by each grid, relevant to the recording interval.

④ Real time data: display the engineering quantity measurement / operation data of the channel, if the current channel is in the alarm state, the measurement / operation data will turn red.

⑤ Real-time Curve: The display value of the current measurement / operation data corresponds to the right end of the curve.

⑥ Alarm Status: From left to right is upper limit HH / upper limit HI / lower limit LO / lower limit LL, green for normal state, red for over-limit alarm.

⑦ Grid: easy for users to estimate time and data values.

⑧ Unit: The engineering units that display the passage are freely configurable.

⑨ Grid Time: The time represented by the current grid.

⑩ Project Digit Number: show the corresponding project bit number / channel serial number of channel, can be configured freely.

- ⑪ Curve scale: a 100-component scale showing the curve.
- ⑫ Display / hide sign: "v" display curve, " × " hidden curve.
- ⑬ Press [left] or [right] to move the cursor; Press [Entry] to perform the cursor channel curve display / blanking operation. Press [Menu] key switch to historical curves picture.

### 3.7 Historical Curve

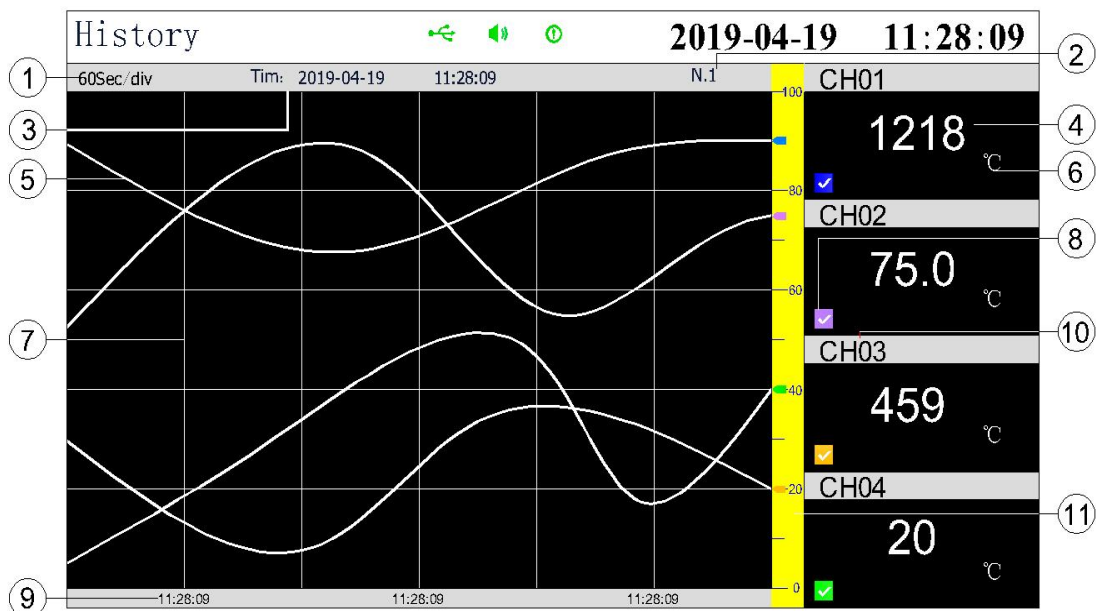

- ① Time Scale: The length of time represented by each grid, relevant to the recording interval.
- ② Display Combination: Current display combination number, freely configurable.
- ③ Recall Time: Set the corresponding recall time date and press confirm key to recall at fixed point.
- ④ Recall Data: The instrument records the channel display value corresponding to the current recall time.
- ⑤ Recall Curve: a section of historical curve recorded in multiple grid time, can have its own configuration curve / data color.
- ⑥ Unit: The engineering units that display the passage are freely configurable.
- ⑦ Grid: Easy for users to estimate time and data values.
- ⑧ Display / hide sign: "v" display curve, " × " hidden curve.
- ⑨ Grid time: The time represented by the current grid.
- ⑩ Project Digit Number: show the corresponding project bit number.
- ⑪ Curve scale: a 100-component scale showing the curve.
- ⑫ Operation: Press [left] or [right] to move the cursor; Press [up key] or [down key] to adjust the value.

### 3.8 Alarm List

| Alm Msg |      |      | 2019-04-19 11:28:09 |                     |
|---------|------|------|---------------------|---------------------|
| Nu      | Chnl | Type | Alm Time            | Recover Time        |
| ▶ 17    | CH1  | HH   | 2019-04-19 07:28:13 | 2019-04-19 07:29:32 |
| 18      | CH4  | HI   | 2019-04-19 07:28:24 | 2019-04-19 07:38:57 |
| 19      | CH2  | HH   | 2019-04-19 07:29:42 | 2019-04-19 07:40:50 |
| 20      | CH1  | LL   | 2019-04-19 07:48:11 | 2019-04-19 08:18:53 |
| 21      | CH3  | LO   | 2019-04-19 07:53:28 | 2019-04-19 08:07:22 |
| 22      | CH1  | LL   | 2019-04-19 09:47:22 | 2019-04-19 09:52:39 |
| 23      | CH1  | HI   | 2019-04-19 09:55:26 | 2019-04-19 10:25:19 |
| 24      | CH2  | LO   | 2019-04-19 10:25:23 | 2019-04-19 11:00:00 |
| R1      |      | R2   |                     | Page: 3/6           |

- ① Pointer: The mark that points to the search result when a sequence number or page number is retrieved.
- ② Serial Number: The record is arranged according to the time, the closer the occurrence time, the more the arrangement, can save up to 48 alarm and cancellation information, single screen can display 8 messages at the same time.
- ③ Alarm Channel: the channel number that produces the current alarm information.
- ④ Alarm type: current channel alarm type, upper limit alarm HH, upper limit alarm HI, lower limit alarm LO, lower limit alarm LL.
- ⑤ alarm / cancellation time: red is alarm time, blue is cancellation time, unreported It shows 20//--//--//: //: //
- ⑥ Relay State: display current relay output state, red in alarm state, green for normal state, black for unmatched relay.
- ⑦ Operation: Press[**left**] key or [**right**] key according to page search alarm information, Press[**up**] key or [**down**] key according to strip search alarm information, press [**menu**] switch to list of power outages picture.

### 3.9 List of power off

| Power Log |                     | 2019-04-19 11:28:09 |  |
|-----------|---------------------|---------------------|--|
| Nu        | Pow Off             | Pow On              |  |
| ▶ 01      | 2019-04-19 07:28:13 | 2019-04-19 07:29:32 |  |
| 02        | 2019-04-19 07:28:24 | 2019-04-19 07:38:57 |  |
| 03        | 2019-04-19 07:29:42 | 2019-04-19 07:40:50 |  |
| 04        | 2019-04-19 07:48:11 | 2019-04-19 08:18:53 |  |
| 05        | 2019-04-19 07:53:28 | 2019-04-19 08:07:22 |  |
| 06        | 2019-04-19 09:47:22 | 2019-04-19 09:52:39 |  |
| 07        | 2019-04-19 09:55:26 | 2019-04-19 10:25:19 |  |
| 08        | 2019-04-19 10:25:23 | 2019-04-19 11:00:00 |  |

R1 R2 Page: 1/3

- ① Pointer: The mark that points to the search result when a sequence number or page number is retrieved.
- ② Serial Number: The record is arranged according to the time, the closer the occurrence time, the more the arrangement, can save up to 24 alarm and cancellation information, single screen can display 8 messages at the same time.
- ③ Power-off / power-on time: red for power-down time, blue for power-on time.
- ④ Relay State: Display current relay output state, red in alarm state, green for normal state, black for unmatched relay.
- ⑤ Operation: Press[left] key or [right] key according to page search alarm information, Press[up] key or [down] key according to strip search alarm information, press [menu] switch to list of power outages picture.

## Chapter 4 Parameter Settings and Auxiliary Operation

### 4.1 Configuration Login

At the same time, hold down [Menu] key and [Entry] key one second later, enter the configuration login screen, select the appropriate operator authority and enter the correct password to enter the configuration screen, Then select the corresponding sub-configuration entry configuration settings, password errors can not enter the configuration screen, the picture description as shown in the figure:

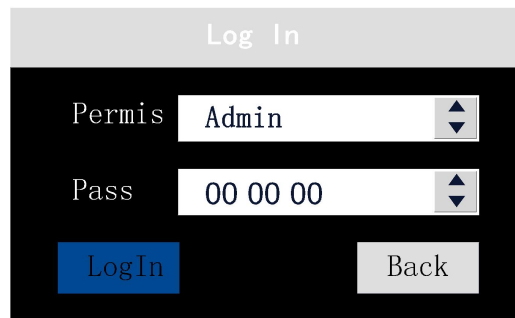

The screenshot shows a 'Log In' screen with a dark background. At the top, the text 'Log In' is displayed in a light gray box. Below this, there are two input fields: 'Permis' with the value 'Admin' and 'Pass' with the value '00 00 00'. Both fields have small up and down arrow icons on their right side. At the bottom, there are two buttons: a blue 'LogIn' button and a gray 'Back' button.

- ① Permission: The operator permission to enter configuration mode, divided into operators and administrators, the permissions are different from the sub-configuration they can enter, operator permissions can only enter the input, backup and print sub-configuration, Administrator permissions can enter any child configuration.
- ② Password: The default initial password for operator permissions is 00 00 00', and the default password for administrator rights is 10 00 00.
- ③ Operation: Press [left] or [right] to move the cursor; Press [up key] or [down key] to select or adjust the value; Press confirm key to perform cursor function.

## 4.2 Configuration Picture

[Login Configuration] decrypted into the [Configuration Screen], the picture description as shown in the figure:

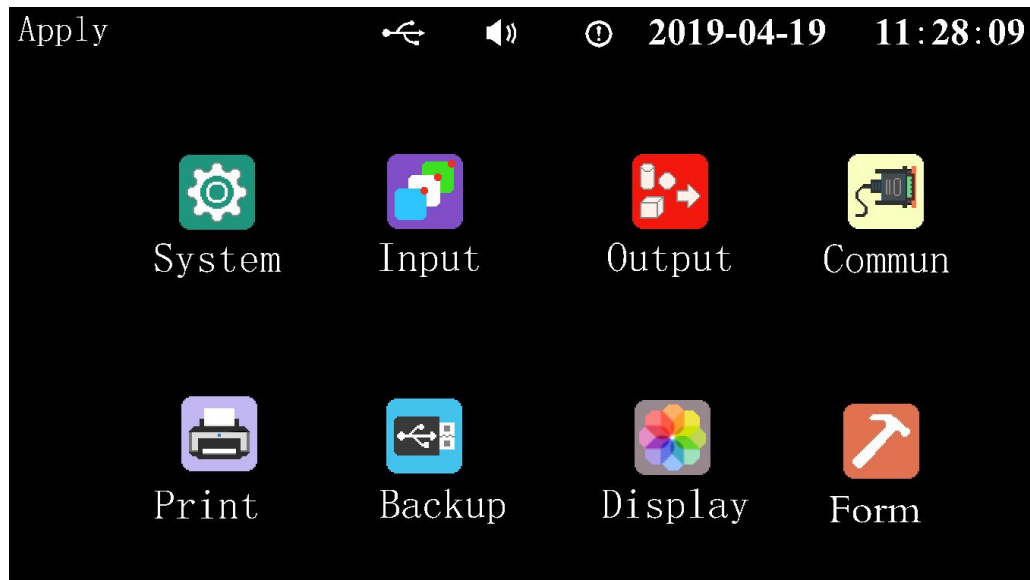

① Configuration: Use hierarchical menu structure, with system configuration, input configuration, output configuration, communication configuration, printing configuration, backup configuration, display configuration, function information and so on.

② Press [to the left] key or [to the right] key to move the cursor. Press [up key] or [down key] to move the cursor; Press confirm key to [Enter] the cursor sub-configuration screen. Press [Exit] key to exit the cursor sub-configuration screen.

### 4.3 System Configuration

Move cursor to [system] entry in [configuration] screen, press confirm key to enter [system configuration], picture description as shown in figure:

The screenshot shows the 'SysSetup' configuration screen. At the top, there is a title bar with 'SysSetup' on the left and navigation icons (back, forward, info) in the center, followed by the date '2019-04-19' and time '11:28:09' on the right. Below the title bar, there are two columns of dropdown menus. The first column contains: 'Dite' (2019/04/19), 'Administ' (10 00 00), 'Interval' (2 S), 'AutoSwit' (0 S), and 'Custom' (Setting). The second column contains: 'Time' (09:27:18), 'Operation' (00 00 00), 'Keysound' (Enable), 'SysMaint' (Clean Pow Inf), and 'Language' (English). Each dropdown menu has a small arrow icon on its right side.

- ① Time date setting: Set system date and time.
- ② Administration Password: administrator permissions login configuration to modify or view parameters of the unique password, the initial default 10 00 00.
- ③ Operation Password: operator login configuration changes or view parameters of the unique password, the initial default of 00 00 00 00.
- ④ Record Interval: Can be set to 1 / 2 / 4 / 8 / 12 / 24 / 36 / 60 / 120 / 180 / 240 seconds. The larger the recording interval, the longer the recording time, conversely, the smaller the recording interval, the shorter the recording time. In general, when the measured signal changes more quickly, the recording interval should be smaller. On the contrary, when the measured signal changes slowly, the recording interval may be larger.
- ⑤ Keystroke sound: the system allows / disables buzzers during keystroke operation.
- ⑥ Auto switch: cycle displays the time period value of each display combination screen.
- ⑦ System Maintenance: The system maintenance function, such as [clear the power off list] or [clear the alarm list] or [restore the default setting]. Once system maintenance is confirmed, the data will be cleared or factory settings will be restored, the process will not.
- ⑧ System Language: Can choose Chinese and English two kinds of languages.
- ⑨ Press [left] or [right] to move the cursor; Press [up key] or [down key] to select or adjust the value; Press confirm to perform cursor location function or edit cursor location data.

### Attention

- ①The operation and management password is the only password that can enter the configuration modification parameter. It is suggested that the user should modify the password as soon as possible after purchasing the instrument and keep it properly.
- ②To change the operator password, log in to the system parameters under the administrator's permission. Operator permissions do not have the permission to change the password.
- ③Factory settings will initialize all configuration information and clear all stored data in the instrument, including historical data, power loss list, alarm list, etc.

## 4.4 Input Configuration

In the configuration screen, move the cursor to the input entry, press confirm key to enter the input configuration, the picture description is as shown in the figure:

The screenshot shows the 'Input' configuration screen with the following parameters and values:

|           |        |           |                |
|-----------|--------|-----------|----------------|
| Chnl Nu : | 01     | ChnlName: | Chnl01         |
| Signal:   | 4-20mA | Unit:     | °C             |
| PoinNum : | 1      | FilteTim: | 0 S            |
| MinRange: | 0.0    | MaxRange: | 100.0          |
| Cut:      | 0.0 %  | Correct:  | k: 1.00 b: 0.0 |
| Burn Out: | Flag   | Flow:     | Enable         |
| CJC Temp: | 26 °C  | Alarm     | Copy Paste     |

- ①Channel serial number / bit number: Channel serial number is limited by hardware, support bit number modification function, bit number modification details see Appendix I [bit number configuration].
- ②Type of signal: support universal analog input such as 4-20mA 0-20mV. The signal type should be the same as the signal of the primary instrument or detection element.
- ③Engineering Unit: user-defined engineering unit, independent of measurement

signal calculation, supporting user-defined expansion unit (1), operating the same number modification function.

④ Digits: the volume of the channel shows a decimal point.

⑤ Filtering Time: The setting of filtering time helps to improve the smoothness of the signal. The longer the filter time is, the smoother the signal is, but the slower the response is.

⑥ Range: user defined range, upper limit and lower limit, can be configured freely. Press confirm key to enter the Auxiliary Interface for quick parameter changes.

⑦ Signal Removal : When the measurement signal is small , the measurement error is relatively large , especially below 1 % , the accuracy will be greatly reduced , and the project will generally be zeroing , i.e . cutting off the small flow . When setting a certain percentage , the signal less than the range percentage is forced to be the lower limit of the range.

⑧ Linear adjustment: allows the user to adjust the deviation value of the display value, display data = measurement data K+ B, generally, the adjustment value should be set to 0.

⑨ Cold end compensation: when the cursor is in the cold end compensation setting box, press confirm key to switch [given] or [external] mode, when in a given mode, The cold end compensation value can be set freely, and the cold end compensation value system can be captured automatically in [external] mode, the system factory default is [external] mode.

⑩ Alarm Configuration: Alarm configuration contains alarm threshold, alarm contact, alarm return difference and other parameters, the parameters are described as follows:

A、 Alarm threshold: the threshold produced by the alarm, which must be within the range of the channel range. This instrument is divided into four categories: upper limit (HH), upper limit (HI), lower limit (LO) and lower limit (LL).

B、 Alarm Contact: relay number, such as contact 01 for relay 01, that is, R1(display in instrument screen) or K1 (display in instrument wiring mode).

C、 Alarm Return Error: when the signal oscillates near the alarm threshold, the relay acts frequently, which sets a difference (lag) for the occurrence and release of the alarm.

⑫ Copy and paste: copy current channel parameter, switch channel serial number paste to another channel.

⑬ Press [to the left] or [to the right] to move the cursor; Press [up key] or [down key] to select or adjust the value; Press confirm to perform cursor location function or edit cursor location data.

## 4.5 Output Configuration

Move the cursor to the output entry in the configuration screen, press confirm key to enter the output configuration, the picture description is as shown in the figure:

The screenshot shows the 'Output' configuration screen. The title bar at the top contains a back arrow, a speaker icon, a power icon, and the date and time '2019-04-19 11:28:09'. Below the title bar, there are six configuration fields arranged in two columns and three rows. Each field consists of a text input box and a dropdown arrow on the right. The fields are: 'Chnl NU' with value '05', 'Output' with value '4-20mA', 'Source' with value 'CH1', 'PosOrNeg' with value 'Ditect', 'MinRange' with value '0.0', and 'MaxRange' with value '100.0'.

- ① Channel serial number: the serial number of the output channel. The number of channels that can be selected is limited by hardware.
- ② Output type: The output signal type selection of the transmission output channel.
- ③ Signal Source: The source sampling channel that specifies the output value of the current transmit output channel.
- ④ Positive and negative effects: under the positive action, the upper limit of the transmission range corresponds to the upper limit of the output current, the lower limit of the transmission range corresponds to the lower limit of the output current when the default range of transmission is positive, and the upper limit of the range of transmission corresponds to the lower limit of the output current under the counter action. The lower limit of the range corresponds to the upper limit of the output current.
- ⑤ The upper and lower limits of the source range: the upper and lower limits of the transmission and output range of the signal source channel [sampling channel] defined by the user.
- ⑥ Action: press [left] or [right] to move the cursor; Press [up key] or [down key] to adjust data or switch selections; Press confirm key to perform cursor location function or edit cursor location data.

## 4.6 Communications Configuration

In the configuration screen, move the cursor to the communication entrance and press the confirmation button to enter the communication configuration.

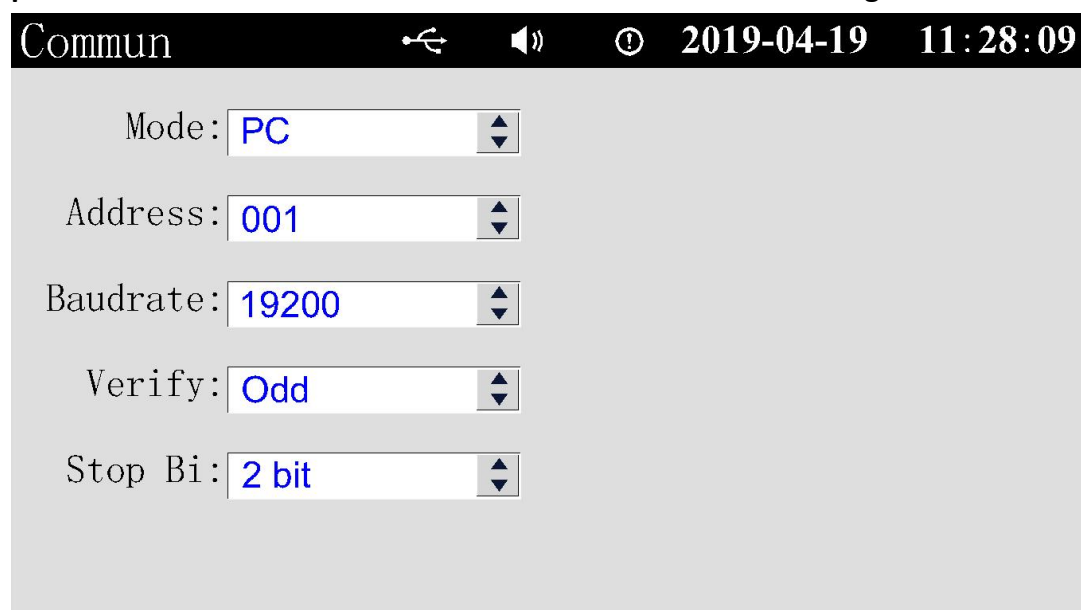

The screenshot shows a configuration screen titled 'Commun'. At the top, there is a status bar with a back arrow, a speaker icon, a clock icon, and the date and time '2019-04-19 11:28:09'. Below the status bar, there are five configuration items, each with a label and a dropdown menu:

- Mode: PC
- Address: 001
- Baudrate: 19200
- Verify: Odd
- Stop Bi: 2 bit

① Online mode: including PC and printer two ways to enter the print configuration must first set the online mode as a printer to be effective.

② Online address: the communication address is used to distinguish when the instrument is made up of the network. It is the identity of the instrument in the network. The host computer software is used to access the instrument. The local address of the same communication network can be set between 001 and 255, and it can not be repeated.

③ baud rate: when the communication mode is 'printer' mode, baud rate can not be changed. PC ways, baud rate can be changed(1200、4800、9600、19200、38400、57600)

④ Verification mode: no check / odd check / even check, default odd check.

⑤ Stop bit: 2 bit / 1 bit, default 2 bit.

⑥ Press [left] or [right] to move the cursor; Press the up arrow key or down button to adjust the data or toggle the selection.

⑦ Communication connection mode:

RS485 connection mode

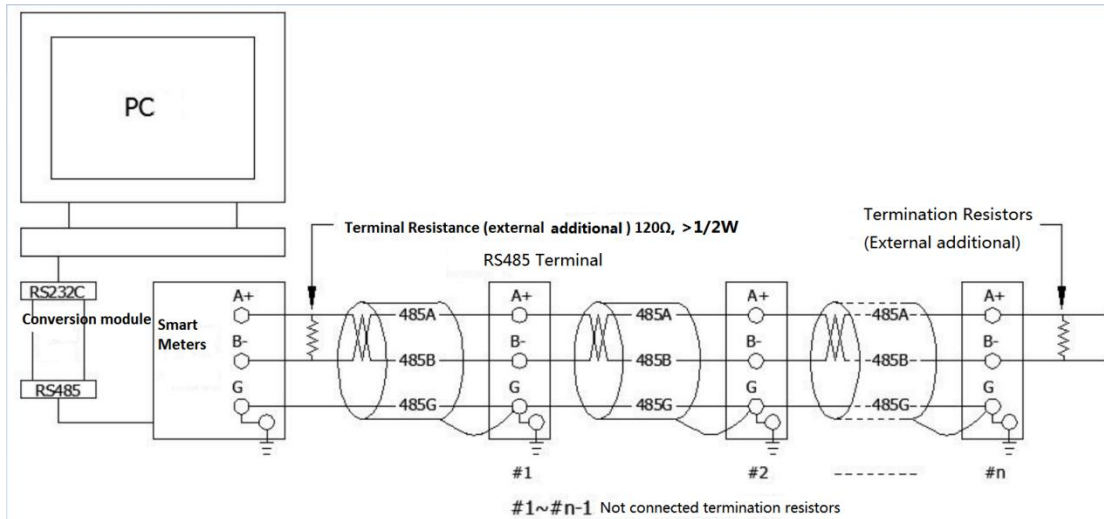

## RS232 connection mode

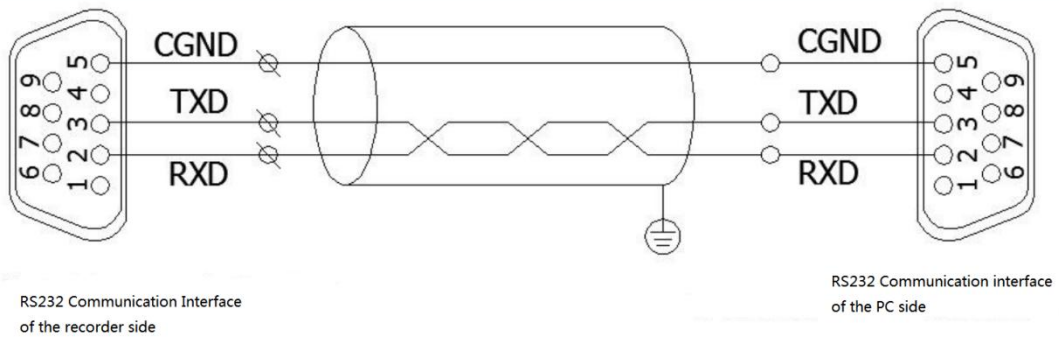

## 4.7 Print Configuration

Move cursor to print entry in [configuration] screen, press confirm key to enter print configuration, picture description as shown in figure:

Print 2019-04-19 11:28:09

PrintChnl: 01 Type: Date

BeginDate: 2019/04/19 BeginTime: 09:28:09

EndDate: 2019/04/19 EndTime: 09:28:11

Interval: 2 S Stop Print

Schedule: 50 %

- ① Print channel: user needs to print data / curve passageway.
- ② Print type: the type of content users need to print, data and curves.
- ③ Print interval: time interval when printing data / curve.
- ④ Print range: start and end date of print data / curve, starting and ending date must be earlier than end time date, otherwise data / curve printing cannot be carried out.
- ⑤ Printing progress: the progress of the current printing process is displayed in real time, the filling area is the current printed part, and the middle value of the progress bar is the percentage of the print progress.
- ⑥ Press [left] or [right] to move the cursor; Press [up key] or [down key] to adjust data or switch selections; Press confirm to jump quickly (cursor at the beginning and end date).

## 4.8 Backup Configuration

Move cursor to backup entry in [configuration] screen, press confirm key to enter backup configuration, picture description as shown in figure:

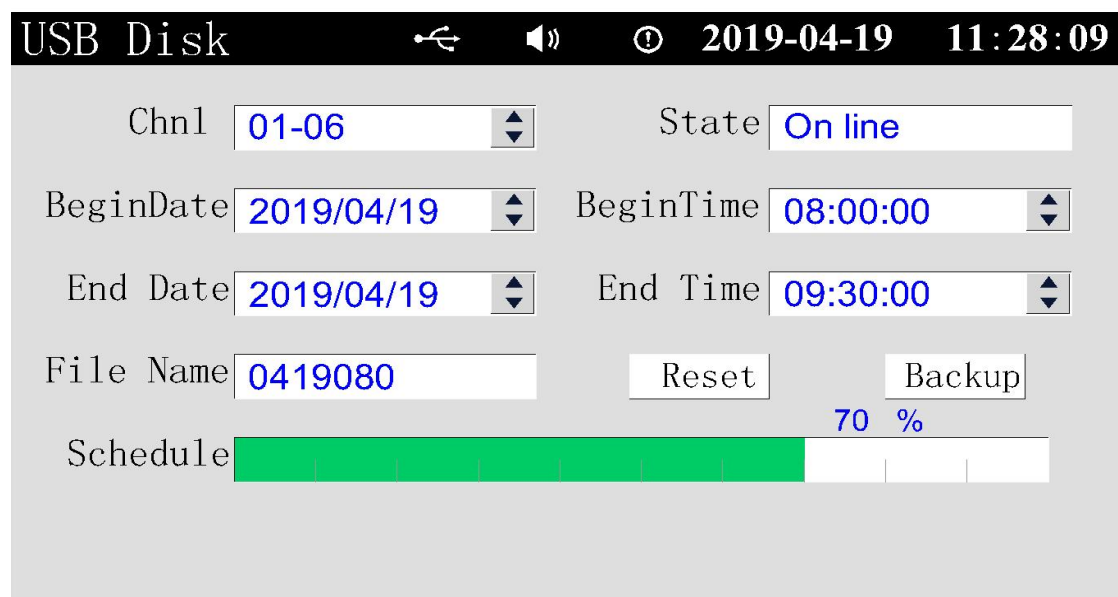

The screenshot shows the 'USB Disk' configuration screen. At the top, there is a header bar with the text 'USB Disk', a USB icon, a speaker icon, a clock icon, and the date and time '2019-04-19 11:28:09'. Below the header, the configuration fields are as follows:

- Chnl: 01-06 (dropdown menu)
- State: On line (text field)
- BeginDate: 2019/04/19 (dropdown menu)
- BeginTime: 08:00:00 (dropdown menu)
- End Date: 2019/04/19 (dropdown menu)
- End Time: 09:30:00 (dropdown menu)
- File Name: 0419080 (text field)
- Buttons: Reset and Backup
- Schedule: A progress bar showing 70% completion, with a green bar and the text '70 %' above it.

① Backup Channel: the channel number that the user needs to back up the historical data. If 01-01 means that only 1 channel is backed up, 01-06 means that 1-6 channels need to be backed up.

② Device Status: display U-disk status, online, offline and error status.

③ Backup Range: date of start and end date of backup data, date of beginning and ending time must be earlier than date of end time, otherwise data backup cannot be made.

④ File Name: backup file name, can not be changed.

⑤ Backup Progress: the progress of the current backup process is displayed in real time, the filling area is the current backup part, and the intermediate value of the progress bar is the percentage of the backup progress.

⑥ Operation: Press [to the left] or [to the right] to move the cursor; Press [up key] or [down key] to adjust data or switch selections; Press confirm to jump quickly (cursor at the beginning and end date).

## 4.9 Display Configuration

Move the cursor to the display entry in the configuration screen, press confirm key to enter the display configuration, the picture description is as shown in the figure:

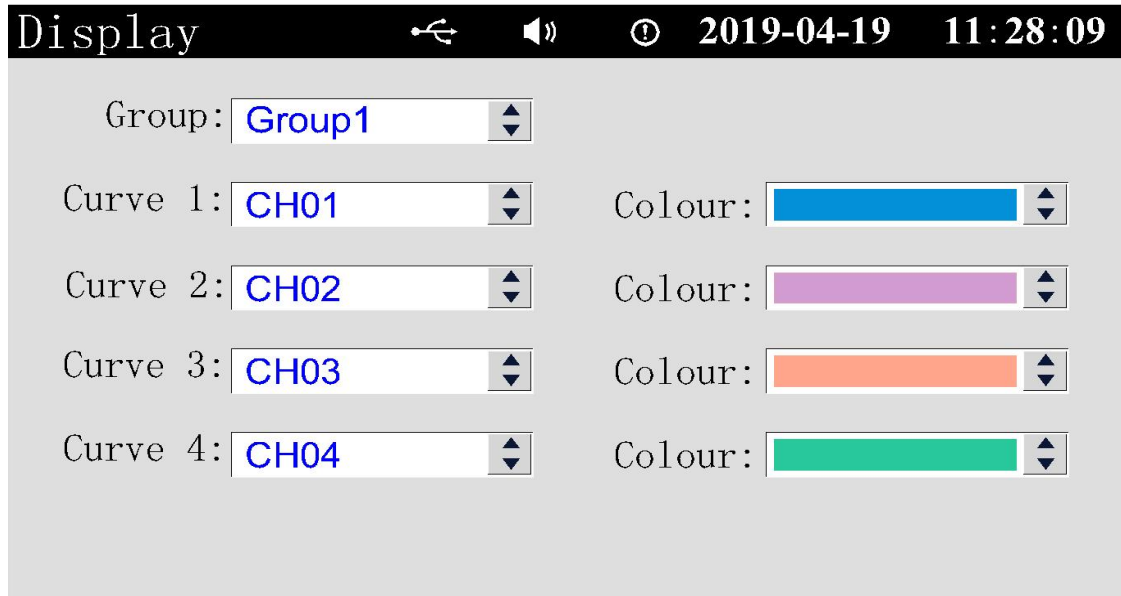

- ① Display Combination: select display combination sequence number.
- ② Channel association: association with any channel combination or closed channel.
- ③ Curve color: select the display color of each curve.
- ④ Press [left] or [right] to move the cursor; Press up or down to switch the selection.

## 4.10 Report Status

|        |            |          |
|--------|------------|----------|
| Form   | 2019-04-19 | 11:28:09 |
| Month  | Mon Cum    | ⏪        |
| Days   | Day Cum    | ⏪        |
| Custom | Cus Cum    | ⏪        |
| Hour   | Hour Cum   | ⏪        |
| Export | Demand     | ⏪        |

- ① Monthly Report: Cumulative traffic value of current every month.
- ② Daily Report: Cumulative traffic value of every day.
- ③ Custom Report: Cumulative traffic value of every shift.
- ④ Hour Report: Cumulative traffic value of per hour.
- ⑤ Export: Set parameters for report export.
- ⑥ Operation: Move the cursor to the desired position, press [Enter] to enter, press [exit] to switch to the configuration screen.

### 4.10.1 Monthly Report

|            |            |          |
|------------|------------|----------|
| Month Logs | 2019-04-19 | 11:28:09 |
| 2019-01:   | 0          |          |
| ▶ 2019-02: | 0          |          |
| 2019-03:   | 0          |          |
| 2019-04:   | 0          |          |
| 2019-05:   | 0          |          |
| 2019-06:   | 0          |          |
| 2019-07:   | 22456      |          |
| 2019-08:   | 0          |          |
| 2019-09:   | 0          |          |
| 2019-10:   | 0          |          |
| 2019-11:   | 0          |          |
| 2019-12:   | 0          |          |

The cumulative monthly report shows the cumulative traffic value of each month within one year. Press [left] or [right] to refresh the latest data, press [Enter] to enter the query setting. The interface is shown as follows.

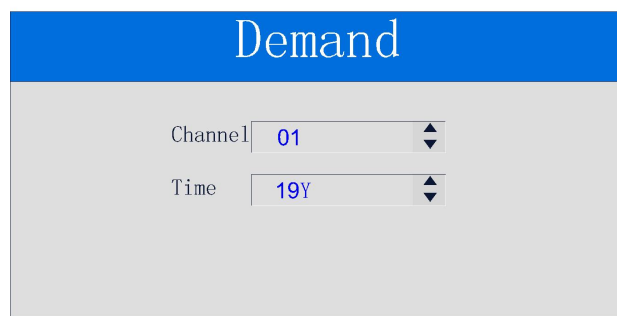

The screenshot shows a window titled "Demand" with a blue header. Below the header, there are two dropdown menus. The first is labeled "Channel" and has "01" selected. The second is labeled "Time" and has "19Y" selected.

- ① Channel: Select the channel that you want to view.
- ② Time: Select the traffic value for the year you want to view, up to 3 years.
- ③ Press [left] to move the cursor, press [Up] or [Down] to modify the data, choose the channel that you need, choose the year you want to view in the time position.

#### 4.11 Note and Assist Interface

The system does not open the function, the operation authority is insufficient, clears the power off or the alarm list, recovers the factory to set and so on the operation will pop up the prompt dialog box, the prompt dialog box is shown in the following figure:



Some parameters can be quickly edited into the auxiliary interface, which is shown above. The auxiliary interface is mainly used for setting the upper and lower limit of alarm, setting up the upper and lower limit of measuring range, etc. Enter the secondary interface (press [Enter key] to enter the auxiliary interface when you are in the corresponding parameter setting box) and quickly adjust the multi-digit values. Once the values set are beyond the range of settings, the system will prompt to exceed the range of the parameters that can be set, Keystroke operation reference "keyboard features".

## Chapter 5 Fault Analysis and Troubleshooting

The paperless recorder adopts advanced production technology and carries out strict test before leaving the factory, which greatly improves the reliability of the instrument. Common failures are generally caused by improper operation or parameter setting. If you find a failure that can not be handled, please record the failure and contact us in time. The following are some troubleshooting and handling measures for this instrument in its daily application:

| Fault Phenomenon                                       | Cause Analysis   | Solution  |
|--|--|---|
| The recorder not working with electricity              | <ul style="list-style-type: none"> <li>① Poor contact with power cord</li> <li>② Power switch is not closed</li> </ul>   | Check power supply  |
| The signal display does not match the actual situation | <ul style="list-style-type: none"> <li>① Signal setting error in configuration</li> <li>② wiring error</li> </ul>  | <ul style="list-style-type: none"> <li>① Inspection configuration</li> <li>② Check signal line</li> </ul>   |
| Alarm Output Abnormal                                  | <ul style="list-style-type: none"> <li>① Alarm limit setting error</li> <li>② Alarm points shared by other channels</li> </ul>   | <ul style="list-style-type: none"> <li>① Reset the limit</li> <li>② Cancel other alarm points</li> </ul>  |
| Problems in distribution output                        | <ul style="list-style-type: none"> <li>① Transmitter and instrument wiring error</li> <li>② Power distribution with multiple transducers exceeding the standard distribution of this instrument</li> </ul> | <ul style="list-style-type: none"> <li>① Correct wiring</li> <li>② Use external voltage stabilizer to supply power</li> <li>③ Use independent power supply</li> </ul>   |
|  | <ul style="list-style-type: none"> <li>③ Interference between digital and analog signals during distribution</li> </ul>  |   |
| USB Transfer Failure                                   | <ul style="list-style-type: none"> <li>① Incorrect start and end time settings</li> <li>② U disk format is incorrect</li> <li>③ U disk incompatibility</li> </ul>  | <ul style="list-style-type: none"> <li>① Setting time correctly</li> <li>② Format U disk to FAT32</li> <li>③ Use a genuine compatible U disk</li> <li>④ Use larger capacity U disk or clear redundant files in U disk.</li> </ul> |

|   |  |   |
|---|--|---|
|   | <p>④ Insufficient spare space on U disk</p> <p>⑤ Misoperation during backup</p>  | <p>⑤ proper operation</p>   |
| <p>No data or abnormal display in USB transfer file</p> | <p>① No data for the time period selected by the user</p> <p>② User changed system time</p> <p>③ User changed signal type</p> <p>④ The user sets the record interval too big, but the backup time is very short</p> <p>⑤ U disk incompatibility</p> <p>⑥ The time period of the data is too long, which exceeds the maximum read time domain of the upper computer software.</p> | <p>① Select the time to have a data segment</p> <p>② Erasing the primary data area</p> <p>③ No impact on data recording</p> <p>④ Record interval is set to be small or backup time is longer</p> <p>⑤ Use a genuine compatible U disk</p> <p>⑥ The time period for backing up the data is smaller, piecewise and batch backup</p> |
| <p>Variable output Problem</p>                          | <p>① Variable output</p>   | <p>① Check the signal source</p>  |

## Appendix 1 Bit Configuration

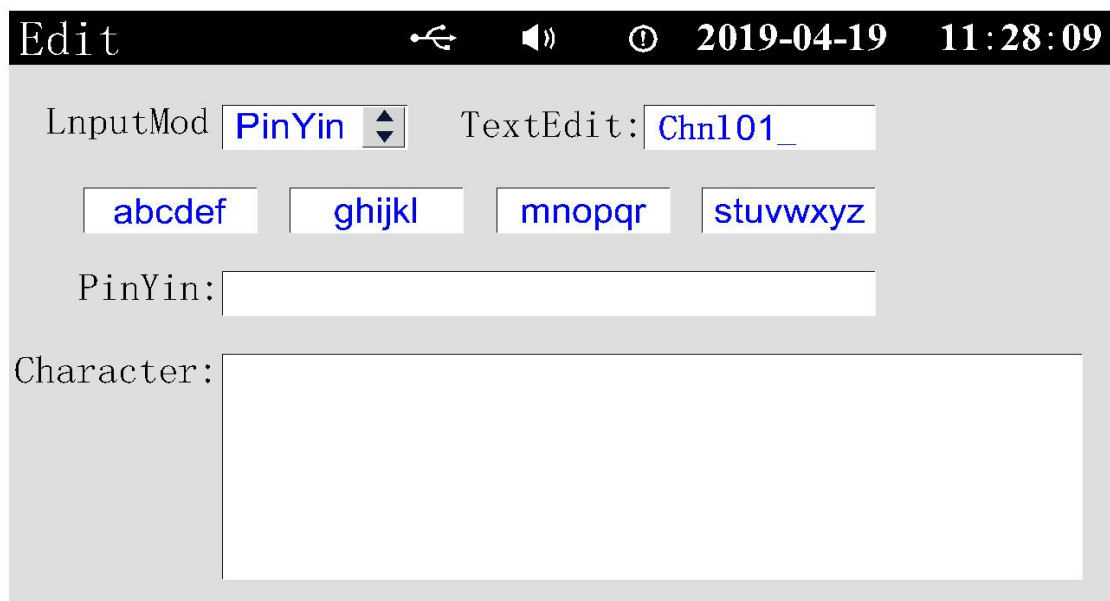

### Input Method

- ⊙ Pinyin: Used for input of Chinese characters.
- ⊙ English / A: used for uppercase English character input;
- ⊙ English / a: Used for lowercase English character input;
- ⊙ Number: Used for numeric character input;
- ⊙ Special Symbol: Used for special symbol input;
- ⊙ Operation: Press [up] key or [down] key to switch input method, press right button to move to channel bit number function box.

### Channel Bit Number:

This area displays the location number, which can display up to 5 Chinese characters or 10 ordinary characters or combinations of Chinese characters and common characters (1 Chinese characters =2 ordinary characters).

- ⊙ Operations: Press [left] key can move to Input method selection box. Press[Right] key can move to Pinyin input selection box.

### Pinyin Input:

when the cursor is in the phonetic selection function box, press [left] key or [right] key can move the cursor to the left and right. press [up] key can move to channel bit number function box. press [down] key can move to Pinyin selection function box. Press [Entry] key can enter the selected letter. Press [Menu] key can cancel the selected letter.

### Pinyin / English / number / symbol selection:

① Pinyin Selection: when the cursor is in the phonetic selection function box, a variety of phonetic combinations may appear after entering Pinyin letters.

② English / number / symbol selection: Press left button, right button, up button or down button can move the cursor to the left, right, up and down. Press [Entry] key choose character.

Chinese character selection:

Select the desired Chinese characters. Operation: press left button or right button to move cursor in the current page, press up button or down button to move cursor up and down. Press [Entry] key choose Chinese characters.

For Example: the first channel requires a bit number of "1# tower temperature", the bit number modification steps are as follows:

① Enter the bit number to modify the screen, the default bit number for "01 channel";

② Press [Up key] or [Down key] to switch input method to [symbol], then press [Right] key to channel bit number function box, press [Menu] function key to drop all default "01 channel", Then press [right] or [Down] to the number selection function box, at this time the cursor stays on the number [#] press the confirmation key, select the back channel number function box horizontal bar automatically move back one, press [right key] to return to the input method function box.

③ Press [Up key] or [Down key] to switch the input method to [Pinyin], press [Right] key to move the cursor to the phonetic selection function box, and then press the [Entry] keys where the letters "l", "v" are located, if the input error, press the [Menu] function key to delete the newly entered letter.



## Appendix 1.2 Pinyin Selection

④After selected pinyin, press the down key to move to the Chinese character selection function box, and then press the right button to move the cursor to 炉.

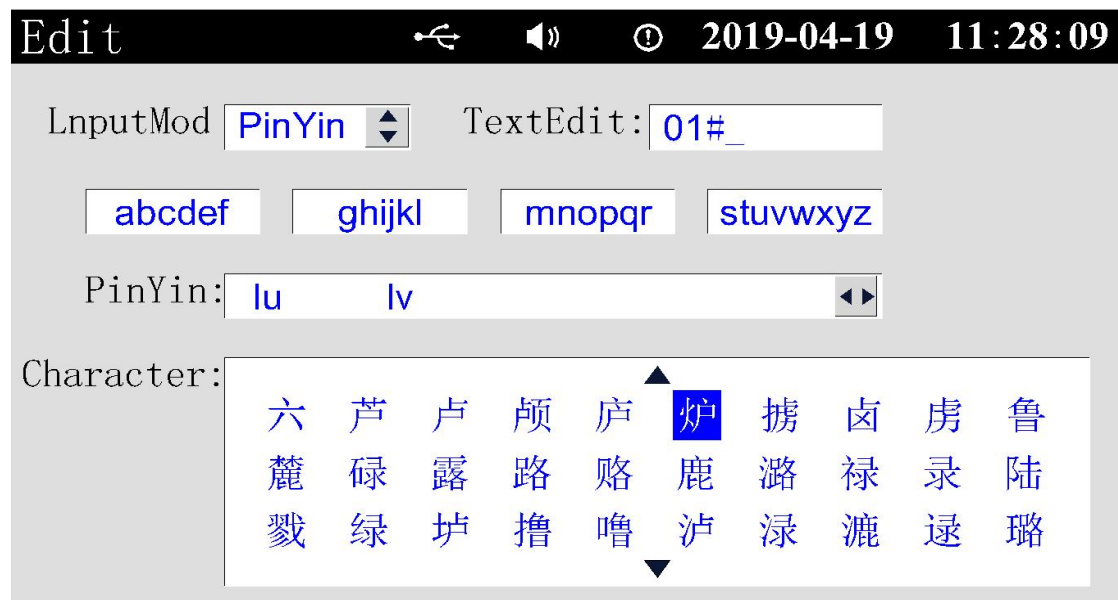

## Appendix 1.3 Chinese characters to choose

⑤After selected the Chinese character, press [confirm] to confirm the Chinese character input. At this time, the horizontal bar at the function box of channel bit number will be automatic

Move back one, similar to repeat the operation ③④steps.

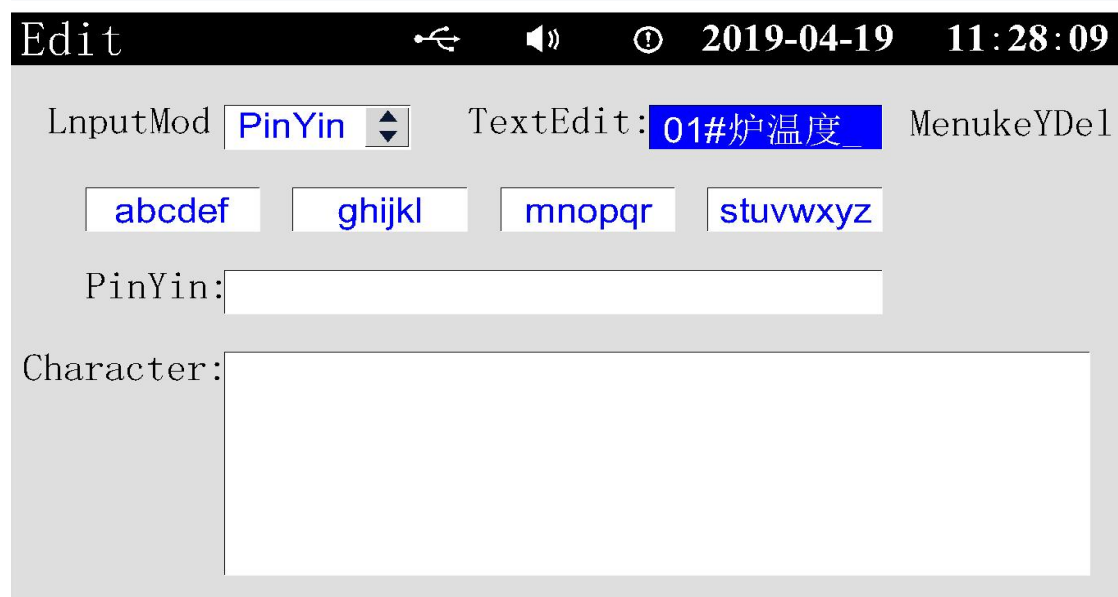

## Appendix 2 Flow Calculation Formula

The flow function needs meter support:

### Appendix 2.1 Mass flow calculation Formula

① difference pressure flow meter: 
$$Q = K * \sqrt{\Delta P * \rho}$$

$K$  : Flow coefficient  $\Delta P$  : Input differential pressure value  $\rho$ : Dielectric density

② Vortex Flow meter:

$$Q = 3600 * I_f * \rho / K$$

$K$  : Flow coefficient  $I_f$  : Vortex frequency  $\rho$ : Dielectric density

③ Linear Flow meter: 
$$Q = K * \rho * \Delta P$$

$K$  : Flow coefficient  $\Delta P$  : Linear signal (volume value)  $\rho$ : Dielectric density

### Appendix 2.2 Flow Coefficient

① When the model is selected as [differential pressure], the coefficient of flow meter is:

$$K = \frac{Q}{\sqrt{\Delta P * \rho}}$$

② When the model is selected [frequency vortex street], the unit of flow coefficient is time/m<sup>3</sup> by default, and the unit and coefficient value of instrument coefficient are set to the unit and coefficient value of Flowmeter (if the Flow meter unit is time/L, the instrument coefficient = Flowmeter coefficient is 1000).

③ When the model is selected [Linear Flow meter], When the medium is not compensated, the volume upper limit is set to the flow value corresponding to the upper limit of linear signal, and the lower limit is set to 0. Both the flow and density takes part in the calculation, When the medium is compensated, the density takes part in the calculation, and the flow coefficient is calculated according to the calculation formula of linear Flowmeter.

## Appendix3 Flow Function

### Appendix3.1 Flow Picture

The flow function needs meter support:

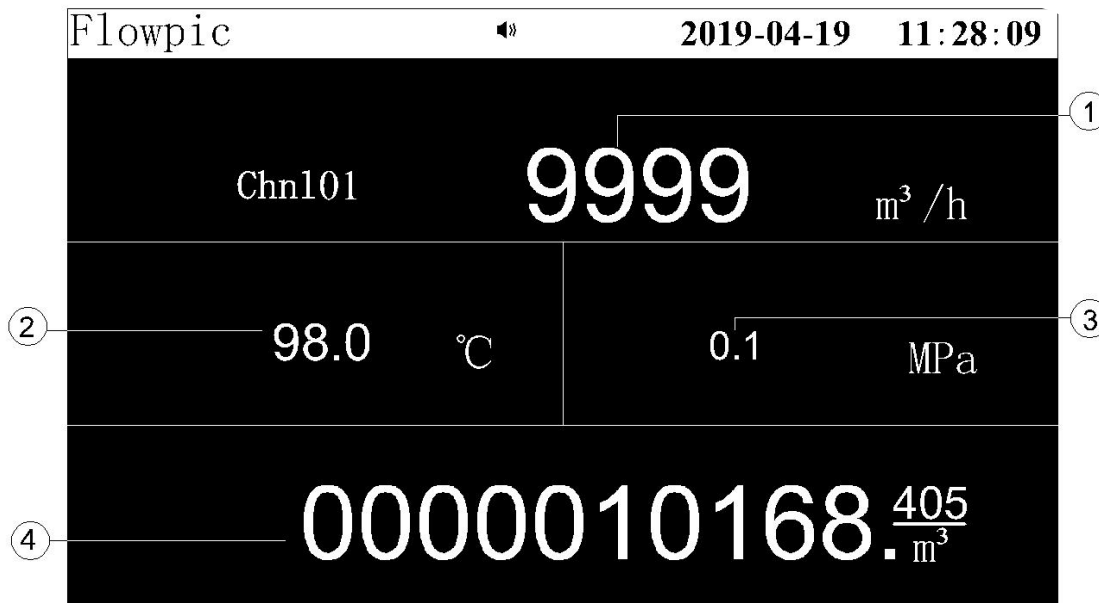

- ① Real Time Data: Cumulative instantaneous value of current traffic.
- ② Real Time Data: Current real-time temperature value.
- ③ Real Time Data: Current real-time air pressure value.
- ④ Real Time Data: Cumulative value of current flow.

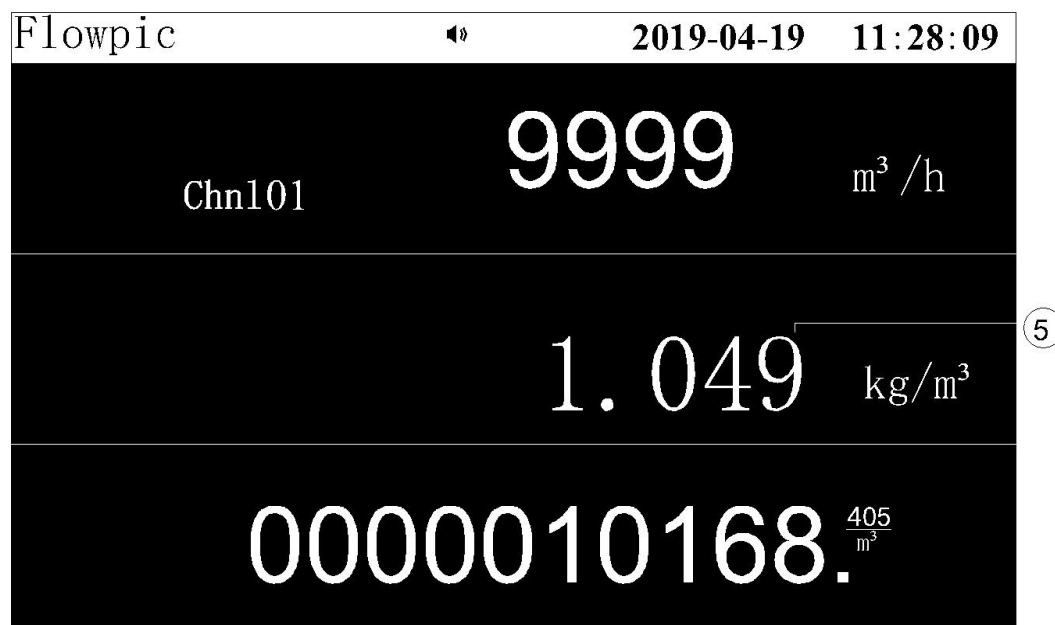

- ⑤ Real Time Data: Current real-time flow density value.
- ⑥ Operation: Press[Left] key to switch flow screen, press [Exit] key to switch flow overall picture.

## Appendix3.2 Custom Configuration

In the [system configuration]screen, move the cursor to the [cumulative custom report] entrance, press [Enter] to enter the [custom configuration] screen description is as below:

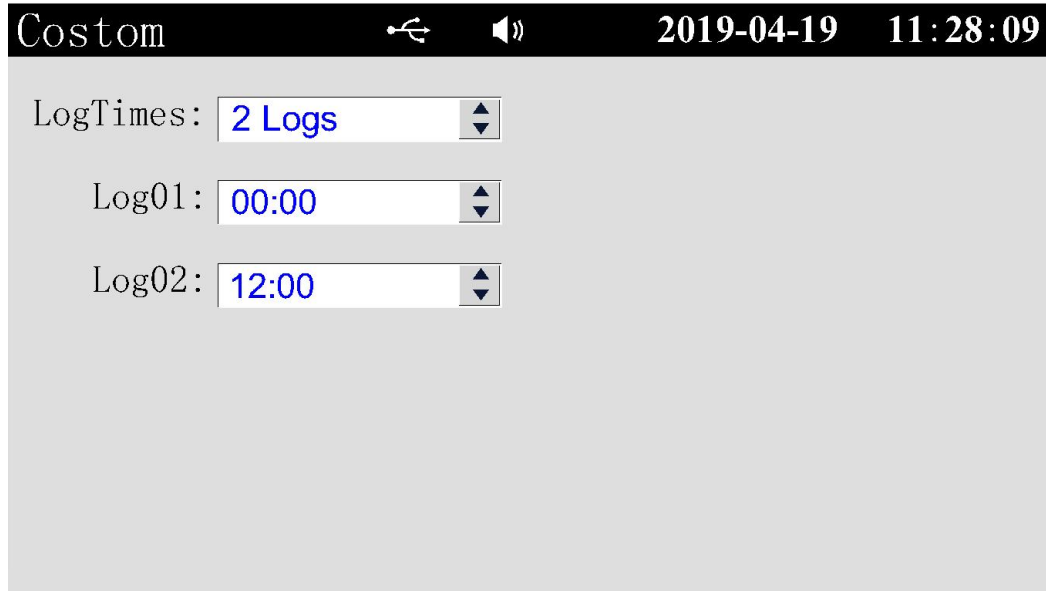

- ① Log Times: Set the costum at the same day.
- ② Log01: The start time of the 1<sup>st</sup> costum.
- ③ Log02: The start time of the 2<sup>nd</sup> costum.
- ④ Operation: Press [left] or [right] to move cursor. Press [up] or [down] to switch select or adjust the value, and press [exit] to quickly exit the system configuration screen.

### Appendix3.3 Flow Configuration

Move the cursor to the flow accumulator in the input configuration screen, press confirm key to enter the flow configuration, the picture description is as shown in the figure:

The screenshot shows a 'Flow' configuration screen with a black header bar containing the word 'Flow', a speaker icon, and the date and time '2019-04-19 11:28:09'. Below the header, there are several input fields with dropdown menus and a 'ClrSum' button. The fields are arranged in two columns:

- FlowMode: Linear
- FlowUnit: m³/h
- MaxRange: 9999
- Medium: SHS
- Temp: Set 20 °C
- StdTemp: 20.00 °C
- Zn/Zf: Zn:1.000 Zf: 0.960
- K: 1.000
- Flow Cut: 0.0 %
- StdDens: 1.000 kg/m³
- Press: Set 0.1 MPa
- Amb: 0.101325 MPa

A 'ClrSum' button is located at the bottom right of the configuration area.

① Flow Units: m³/h, m³/min, m³/s, L/h, L/min, L/s, t/h, t/min, t/s, kg/h, kg/min, kg/s, k m³/h, N m³/h, kN m³/h.

② Flow Model: Different flowmeter can choose different calculation model, the meter temporarily provide four calculation model, the differential pressure type model is suitable for the differential pressure type flowmeter, such as standard orifice, standard nozzle and etc. Frequency vortex model is suitable for the pulse frequency type flowmeter such as vortex, turbine flowmeter, linear model is suitable for the current output type vortex flowmeter, electromagnetic flowmeter, single cumulative type model is suitable for the pure accumulation channel. For mass flow calculation formula, please see appendix 2.

① Rooting Type: When in differential pressure model, can choose: instrument rooting or differential pressure transmitter rooting.

② Input Method: When in frequency model, can choose: count frequency values or count pulse number.

③ Flow Units: m³/h, m³/min, m³/s, L/h, L/min, L/s, t/h, t/min, t/s, kg/h, kg/min, kg/s, k m³/h, N m³/h, kN m³/h, Units also participate in calculate.

④ Flow Range: User's custom traffic range, can free configuration

⑤ Media compensation: Medium compensation can be divided into

uncompensated, general gas, superheated steam, saturated steam (temperature), saturated steam (pressure), natural gas and hot water. For the specific meanings of each compensation type, please see appendix 4 .

- ⑥ **Flow Removal:** When the measured value is smaller than the range multiplied by the flow coefficient, it's 0, otherwise it's not removal.
- ⑦ **Temperature Channel:** Select source channel when in the external compensatory, set a given compensation value when in the internal given.
- ⑧ **Pressure Channel:** Select source channel when in the external compensatory, set a given compensation value when in the internal given.
- ⑨ **Standard Density:** In standard condition (such as: 20.00°C, 0.000Mpa (pressure of meter) ) fluid density, unit: Kg/m<sup>3</sup>.
- ⑩ **Standard Temperature:** Refers to the temperature corresponding to the volume flow after compensation. When the calculated result is volume flow, the rated temperature shall be set, and the parameters shall be determined by the user. The default value of the meter is 20.00°C. The result of mass flow is independent of the standard temperature.
- ⑪ **Standard Pressure:** Refers to the pressure corresponding to the volume flow after compensation. When the calculated result is volume flow, the rated pressure shall be set, and the parameters shall be determined by the user. The default value of the meter is 0.000Mpa. The result of mass flow is independent of the standard pressure.
- ⑫ **Coefficient of compressibility Zn and Zf:** Zn is the compressibility of gas under standard conditions, Zf is the compressibility of gas in flow state.
- ⑬ **Remove Accumulation:** Remove all before accumulated data of the current channel. This meter supports up to 6 channels of flow accumulation.
- ⑭ **Operation:** Press [left] or [right] to move cursor.  
Press [up] or [down] to adjust data or toggle selection.  
Press [enter] to perform the function or edit the data where the cursor located.  
Press [menu] to toggle decimal digits (the cursor should be at the range)  
Press [exit] to exit the subconfiguration quickly.

## Appendix4 Types of compensation and gas density in common use

### ① No compensation

When the system does not have temperature and pressure compensation, the density is fixed at 1.000kg / m by default.

### ② General gas

The purpose of general gas compensation is to convert the working condition volume into the volume flow rate under the standard condition.

The equation of state of general gas accords with the equation of state of ideal gas, and the relation between the density of working condition and the density of standard condition accords with the following formula:

$$\rho_f = \rho_n * \frac{(273.15 + T_n)(0.10136 + P_f)}{(273.15 + T_f)(0.10136 + P_n)}$$

Standard temperature  $T_n = 20.00^\circ\text{C}$  Standard pressure  $P_n = 0.10136\text{Mpa}$

$T_f$  Operating temperature,  $P_f$  Working pressure (gauge pressure)

### ③ Saturated Steam

The purpose of compensation for saturated steam is to obtain mass flow. According to the saturated steam pressure (or temperature) density meter to find the working condition density, realize the pressure (or Temperature) compensation. At this point, the density in the orifice plate of the flow model is input according to the actual input. Pressure (or temperature) density obtained by checking saturated steam pressure (or temperature) density table.

### ④ Superheated Steam

The purpose of compensation for superheated steam is to obtain mass flow.

The temperature and pressure compensation is realized by checking the working condition density according to the superheated steam density meter.

### ⑤ Natural Gas

The purpose of natural gas compensation is to convert the working condition volume into the volume flow rate under the standard condition. The relation between the working condition density and the standard density conforms to

the following formula:

$$\rho_f = \rho_n * \frac{(273.15 + T_n)(0.10136 + P_f)}{(273.15 + T_f)(0.10136 + P_n)} * \frac{Z_n}{Z_f}$$

Standard temperature  $T_n = 20.00 \text{ }^\circ\text{C}$  ,Standard pressure (gauge pressure)  $P_n = 0.000\text{Mpa}$

$T_f$  Operating temperature,  $P_f$  Working pressure (gauge pressure),  $Z_n$  For the compressibility of natural gas in the standard state ,  $Z_f$  coefficient of natural gas in flowing state.

#### Appendix 4.2 Common Gas Density

The standard densities of commonly used gases at 1 standard atmospheric pressure and 20  $^\circ\text{C}$  are as follows.(unit  $\text{kg /m}^3$ ):

Air (dry): 1.2041 nitrogen: 1.1646 oxygen: 1.3302

Helium: 0.1664 hydrogen: 0.0838 Krypton: 3.4835

Methane: 0.6669 ethane: 1.2500 propane: 1.8332

Ethylene: 0.9686 propylene: 1.7495 carbon monoxide: 1.165

Carbon dioxide: 1.829 hydrogen Sulfide: 1.4169 sulfur dioxide: 2.726

## Appendix 5 Examples of traffic usage

**Example 1: measurement of mass flow of superheated steam with standard orifice plate**

**Known:** differential pressure sensor: Two-wire 4-20mA differential pressure transmitter, the instrument needs to be square, Measuring range 0.000 KPA, corresponding volume flow range 0~500m<sup>3</sup>/h Pressure sensor: two-wire 4-20mA transmitter, measuring range 0.00-0.50 MPA

**Temperature sensor:** Pt100

**Working condition:** 230 °C / 0.3MPa (gauge pressure), corresponding to maximum flow rate 500m<sup>3</sup>/h

**Settings: input configuration:**

- ① Signal type selection [4~20mA]
- ② Engineering Unit selection [KPA]
- ③ The lower limit of the range is 0.000, the upper limit of the range is 4.000
- ④ Other parameters are set according to need [the alarm configuration in the input configuration of open flow operation channel is called flow alarm]

**Flow Accumulation:**

- ① Model selection [differential pressure]
- ② Prescription type selection [native prescription]
- ③ The unit of flow: [Kg / h]
- ④ Instrumentation coefficient K: [330.8]
- ⑤ Upper limit of flow range, set according to actual mass flow range
- ⑥ Medium - compensated selection of superheated steam boiler

**Note:** Flow coefficient calculation process

The results show that the superheated steam has a density of 1.7513 kg / m<sup>3</sup> (3) under the condition of 230 °C / 0.3 MPA (gauge pressure).

$$K = \frac{Q}{\sqrt{\Delta P \rho}} = \frac{500 * 1.7513}{\sqrt{4 * 1.7513}} = 330.8$$

**Example 2: Volume flow of water measured by electromagnetic Flowmeter**

**Known:** electromagnetic sensor: Two-wire 4-20mA transmitter, corresponding flow range 0.00~2500m<sup>3</sup> / h

**Setup: Enter configuration:**

- ① signal type selection [4~20mA]
- ② engineering units select [m<sup>3</sup> / h]
- ③ the lower limit of the range is [0.00], the upper limit of the range is [25.00]
- ④ other parameters are set as needed

**Flow accumulation:**

- ① model selection [linear]

- ② flow unit selection [m<sup>3</sup> / h]
- ③ flow coefficient set to [1.000]
- ④ upper limit of flow range set to [25.00]
- ⑤ medium compensation selection [no compensation]
- ⑥ Other parameters are set as required



